

(19) 日本国特許庁 (J P)

(12) 公開特許公報 (A)

(11) 特許出願公開番号

特開2000-162192

(P2000-162192A)

(43) 公開日 平成12年6月16日 (2000.6.16)

(51) Int.Cl. ⁷	識別記号	F I	キーワード(参考)	
G 0 1 N	29/14	G 0 1 N	29/14	2 G 0 4 7
G 0 1 H	11/06	G 0 1 H	11/06	2 G 0 6 4
G 0 1 M	3/02	G 0 1 M	3/02	G 2 G 0 6 7
	3/24		3/24	A

審査請求 未請求 請求項の数 3 O L (全 11 頁)

(21) 出願番号 特願平10-336745

(22) 出願日 平成10年11月27日 (1998. 11. 27)

(71) 出願人 000003713

大同特殊鋼株式会社

愛知県名古屋市中区錦一丁目11番18号

(72) 発明者 山田 龍三

愛知県知多市大草四方田48番地の1

(72) 発明者 堀尾 浩次

愛知県東海市加木屋町南庭持18

(72) 発明者 冷水 孝夫

愛知県名古屋市天白区表山2丁目311番地

八事サンハイツ501

(74) 代理人 100095669

弁理士 上野 登 (外1名)

最終頁に続く

(54) 【発明の名称】 拡張時の品質監視方法

(57) 【要約】

【課題】 鋼管の拡張時に発生した品質異常の発生或いはその品質異常の程度を判定し、リモートで監視することができる拡張時の品質監視方法を提供することにある。

【解決手段】 拡張マンドレル20が鋼管30の内部を移動しながら拡張する際に、鋼管の振動を検出するAEセンサ10を鋼管に当接させて設け、AEセンサ信号の振幅が増大したこと、AEセンサ信号の振幅の増大した回数若しくはAEセンサ信号の振幅の増大した時間を検出し、その検知信号に基づいて、前記鋼管30の品質異常の発生若しくはその品質異常の程度を判定するようにした。

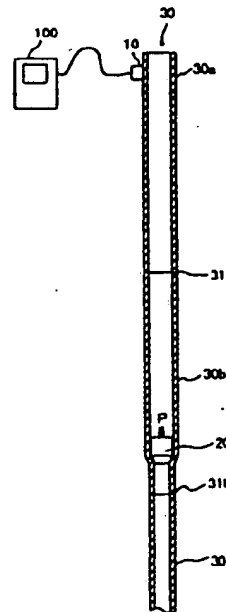

【特許請求の範囲】

【請求項1】 鋼管の拡張時に該鋼管の振動を検出するA Eセンサを鋼管に当接させて設け、拡張マンドレルが鋼管の内部を移動しながら拡張する際に、A Eセンサ信号の振幅が増大したこと、A Eセンサ信号の振幅の増大した回数若しくはA Eセンサ信号の振幅の増大した時間を検知し、その検知信号に基づいて前記鋼管の品質異常の発生を判定するようにしたことを特徴とする拡張時の品質監視方法。

【請求項2】 前記品質異常を判定した際に検知されるA Eセンサ信号の振幅の大きさ、A Eセンサ信号の振幅が増大した回数若しくはA Eセンサ信号の振幅の増大した時間に基づいて前記鋼管の品質異常の程度を判定するようにしたことを特徴とする請求項1に記載の拡張時の品質監視方法。

【請求項3】 拡張マンドレルが鋼管の内部を移動しながら拡張する際に検出されるA Eセンサの信号を増幅すると共に、A Eセンサ信号の振幅の連続的な減少に応じて前記増幅の度合を高め、A Eセンサの振幅の連続的な増加に応じて前記増幅の度合を低下させるようにしたことを特徴とする請求項1又は2に記載される拡張時の品質監視方法。

【発明の詳細な説明】

【0001】

【発明の属する技術分野】本発明は、拡張時の品質監視方法に関し、特に長尺の鋼管等を拡張するときに鋼管の継目等に発生するクラックやピンホール等の品質異常を監視するのに好適な拡張時の品質監視方法である。

【0002】

【従来の技術】従来、鋼材による長尺管を拡張する際には、拡張マンドレルを使用して拡張することが行なわれている。これは、図1に示したように、長尺管30の一方の開口端より拡張マンドレル20を挿通し、所定の荷重Pを印加してこの拡張マンドレル20を長尺管30に押し込むことにより、長尺管30の内壁面を外方へ押し、拡張していくものである。

【0003】ところで、この拡張加工によって鋼管に例えばひび割れのような品質異常が発生する場合がある。特に、例えばメカジョイント、溶接又は拡散接合等による接合部分を有する鋼管の拡張においては、その接合部分に品質異常が発生しやすい。このような品質異常を検出するために、従来、例えば、超音波を被検査体に放射し欠陥面と端面との反射波の違いにより、内部欠陥を発見する超音波探傷法や、被検査体にX線を当てて、その透過放射線をフィルム感光させて、その感光像から欠陥を検出するX線探傷法といった非破壊検査が行なわれている。

【0004】しかし、これらの検査方法を行なうには検査装置の少なくとも一部分を検査したい部位に設置されなければならないという問題があり、これは、鋼管が長

くなるほど大きな問題となる。また、これらの検査方法では、拡張作業中の部位では行なうことができず、少なくとも検査部位の拡張が終了した後に行なわなければならないという問題もあった。即ち、従来の検査方法では、拡張をした後に、検査する部位に検査装置の少なくとも一部を設置して検査を行なう必要があった。

【0005】一方、従来、地下の石油等を吸い上げるための油井川パイプを設置するにあたり、その埋設コストを下げるため、径の比較的小さい鋼管を地中に挿入した後、拡張マンドレル等を高圧で後方からの押圧により挿通させて拡張する技術が知られている。このように拡張された鋼管を従来の方法で検査するためには、該鋼管は地中に埋設されているため、鋼管の外壁面に検査装置等を設置することが困難であり、検査装置を鋼管の外壁面に沿って長さ方向に移動させることは更に困難であったため、鋼管の内部を検査装置を移動させて検査する必要があるが、拡張後であってもその管径は小さく、またその全管長は数キロメートルに及ぶこともあるため、鋼管全体について従来の方法で品質異常の検査をすることは非常に困難であるという問題があった。

【0006】

【発明が解決しようとする課題】本発明の解決しようとする課題は、鋼管の拡張作業中に監視装置が静止した状態で鋼管の品質異常を判定することができ、品質監視装置から離れた部位の品質異常の発生又は程度を判定することができ、かつ、該鋼管の品質異常発生とほぼ同時にその発生を検出することができる拡張時の品質監視方法を提供することにある。

【0007】

【課題を解決するための手段】この課題を解決するために本発明に係る拡張時の品質監視方法は、鋼管の拡張時に該鋼管の振動を検出するA Eセンサを鋼管に当接させて設け、拡張マンドレルが鋼管の内部を移動しながら拡張する際に、A Eセンサ信号の振幅が増大したこと、A Eセンサ信号の振幅の増大した回数若しくはA Eセンサ信号の振幅の増大した時間を検知し、その検知信号に基づいて前記鋼管の品質異常の発生を判定するようにしたことを要旨とするものである。

【0008】このように行なう本発明の拡張時の品質監視方法によれば、拡張マンドレルが鋼管の内部を移動しながら拡張する際の鋼管面及び鋼管内部に発生する振動を、鋼管に設置されたA Eセンサによって検出し、前記A Eセンサ信号の振幅が増大したことを検出した場合に品質異常が発生したと判定し、前記A Eセンサの信号の振幅が増大した回数が予め設定した回数に達したことを検出したときに品質異常が発生したと判定し、若しくは、前記A Eセンサの信号の振幅が増大した時間が予め設定した時間に以上になったことを検出した場合に品質異常が発生したと判定するものである。

【0009】また、請求項2に記載の発明のように、前

記品質異常を判定した際に検知されるAEセンサ信号の振幅の大きさ、AEセンサ信号の振幅が増大した回数若しくはAEセンサ信号の振幅が増大した時間に基づいて前記鋼管の品質異常の程度を判定するようによれば、前記AEセンサ信号の振幅の大きさに基づいて前記鋼管の品質異常の程度を判定でき、前記AEセンサ信号の振幅が増大した回数に基づいて前記鋼管の品質異常の程度を判定することができ、若しくは、AEセンサ信号の振幅が増大した時間に基づいて鋼管の品質異常の程度を判定することができる。

【0010】更に、請求項3に記載の発明のように、拡張マンドレルが鋼管の内部を移動しながら拡張する際に検出されるAEセンサの信号を増幅すると共に、AEセンサ信号の振幅の連続的な減少に応じて前記増幅の度合を高め、AEセンサの振幅の連続的な増加に応じて前記増幅の度合を低下させるようにすると良い。

【0011】このように行なう本発明の請求項3に記載の拡張時の品質監視方法によれば、拡張マンドレルが鋼管の内部を移動しながら拡張する際に検出されるAEセンサの信号を増幅すると共に、拡張により発生する振動がAEセンサまで伝搬することによって生じる減衰が大きくなると前記増幅の度合を増加させ、前記減衰が低下すると前記増幅の度合を減少させるように調整するので、拡張により発生する振動がAEセンサまで伝搬することによって生じる減衰が補正され、該補正されたAEセンサ信号に基づいて品質監視が行なわれる。

【0012】ここで、増幅の度合の変化をAEセンサ出力振幅の連続的な減少又は連続的な増加に応じて行なうこととしているのは、拡張により発生する振動の大きさが比較的安定しておりAEセンサの出力振幅が連続的に変化する部位の拡張振動を基準とすることを意味し、例えば、異常発生時のAEセンサ信号振幅の変化のように非連続的な振幅変化については前記増幅度を追従させないことを意味する。このように非連続変化部分を除いたAEセンサ信号振幅の変化に基づいて補正をすることにより、品質異常等が発生して監視時刻のAE信号振幅が一時的に増大又は減少しても誤った補正をすることなく、減衰を適確に補正する。

【0013】

【発明の実施の形態】以下に本発明の好適な実施の形態を図面を参照して詳細に説明する。図1は、本発明に係る鋼管の拡張時の品質監視方法の概念を説明するために示した概略構成図である。長尺管30については、断面を示している。該長尺管30は、比較的短い鋼管30a、30b、30c・・・が接合部31a、31b・・・において接合されたものである。図においては、鋼管の3本分しか示されていないが、更に下方に続いている。

【0014】拡張マンドレル20は図示のようにテーパ部分と円柱部分とを有し、後方（図面においては上方）

から荷重Pを負荷され、前方（図面においては下方）に進行しながら前記テーパ部分により長尺管の内壁面を半径方向外方に押し広げて、前記長尺管30を拡張するものである。AEセンサ10は長尺管の外側面に接触する状態で設置され、前記拡張が行われているときの該外側面の振動を信号に変換するものであり、監視装置本体100に接続されて該信号を出力する。

【0015】図2は、本発明に適用される品質監視装置の信号処理構成例を示す制御ブロック図である。(a)に示す品質監視装置本体100においては、AEセンサ10は絶対値処理部101に接続され、絶対値処理部101は比較処理部103に接続され、異常判定基準値設定部102も比較処理部103に接続され、比較処理部103は告知手段110に接続される。

【0016】前記絶対値処理部101はAEセンサ10の出力信号の直流分を取り除き絶対値化した信号を出力する。前記異常判定基準値設定部102はAEセンサ10の信号振幅の大きさを判断するための閾値である異常判定基準値Th1を設定する部分であり、異常判定基準値Th1は、異常なく拡張が行なわれている時のAEセンサ信号振幅と品質異常が発生したときAEセンサ信号振幅との間の値になるように設定されればよい。

【0017】例えば、基準値設定つまみを設けて拡張対象の鋼管の種類に応じて予め実験的に得られた異常判定基準値を操作者が設定するようにしても良いが、ここでは、該長尺管30の拡張加工を始めた初期段階の時刻t_sのAEセンサ信号振幅A_sに予め設定した係数k1（但し、k1>1）を乗じた値を自動的に設定する様にする。

【0018】前記比較処理部103は、絶対値処理部101から入力される信号を前記異常判定基準値Th1と比較して、絶対値処理部101の信号が異常判定基準値Th1を超えた場合に高値発生信号を出力する。告知手段110は、前記高値発生信号が入力されたときに、品質異常が発生したものと判定し、その旨を音声或いは表示によって操作者に通知する。

【0019】このようにして、(a)に示すように構成される品質監視装置本体100によって品質監視をすれば、AEセンサ10の信号は直流分を除去され整流され振幅を取得されて、AEセンサ10の信号振幅が異常判定基準値を超えた場合に異常発生が告知される。

【0020】(b)に示す品質監視装置本体100は、図からもわかるように、前記(a)に示す品質監視装置の構成の比較処理部103と告知手段110との間にパルス計数部104が介設されたものである。パルス計数部104は、比較処理部103及び告知手段110と接続される。そして、比較処理部103から受けた前記高値発生信号の回数を計数し、その回数が予め設定した回数以上になった場合に、品質異常発生信号を出力する。ここでは、高値発生信号の発生回数が2回以上になった

ときに、品質異常発生信号を出力することにする。

【0021】従って、(b)に示すように構成される品質監視装置本体100によって品質監視をすれば、AEセンサ10の信号は直流分を除去され整流されてその振幅を取得されて、AEセンサ10の信号振幅が異常判定基準値を超えた回数が2回以上の場合に、品質異常発生旨が告知される。

【0022】更に、この場合に、パルス計数部104は、前記品質異常発生信号に加えて、高値発生信号の回数を告知手段110に伝送し、告知手段110は品質異常発生旨及び高値発生信号の回数に応じた品質異常の程度を告知するように構成しても良い。例えば、高値発生回数そのものを告知するようにしても良いが、ここでは、2回ないし3回の場合には異常の程度が「弱」である旨を、4回ないし5回の場合には異常の程度が「中」である旨を、6回以上場合には異常の程度が「強」である旨を告知するようにする。

【0023】(c)に示す品質監視装置本体100は、(a)に示す品質監視装置にピーク値検出部107を増設したものである。ピーク値検出部107には絶対値処理部101の出力及び比較処理部103の出力が入力されると共に、告知手段110に接続される。ピーク値検出部107は、前記比較処理部103から前記高値発生信号が出力された場合に、そのときの絶対値処理部101の出力のピーク値を保持し、前記告知手段110に出力する。

【0024】そして、告知手段110は、品質異常の発生旨及び前期ピーク値に基づいて品質異常の程度を告知する。例えば、ピーク値の大きさそのものを告知するようにしても良いが、ここでは、ピーク値の大きさにより異常の程度を「強」、「中」又は「弱」に判別し、その判別結果を告知するようにする。

【0025】(c)に示すように構成される品質監視装置本体100によって品質監視をすれば、AEセンサ10の信号は直流分を除去され整流されて振幅を取得されて、AEセンサ10の信号振幅が異常判定基準値 $Th1$ を超えた場合には、異常発生旨と該品質異常が発生したときのAEセンサ信号振幅のピーク値に基づく品質異常の程度とが、音声又は表示によって通知される。

【0026】(d)に示す品質監視装置本体100は、(a)に示す品質監視装置の絶対値処理部101と比較処理部103との間に包絡線検波部106を増設し、比較処理部103と告知手段110との間にパルス幅判定部108を増設したものである。前記包絡線検波部106は、絶対値処理部101の出力信号の各種大値を結ぶ包絡線信号を出力し、比較処理部103に伝達する。比較処理部103は、包絡線検波部106の出力が前記異常判定基準値 $Th1$ よりも大きい時に高値発生信号を告知手段110に出力する。パルス幅判定部108は前期高値発生信号の時間が所定の時間よりも長いときには、

異常発生旨及び前記高値発生時間の長さを告知手段110に伝達する。

【0027】そして、告知手段110は、品質異常の発生旨及び前記高値発生信号時間の長さに基づいて品質異常の程度を告知する。例えば、前記高値発生信号時間の長さそのものを告知するようにしても良いが、ここでは、前記高値発生信号時間の長さにより異常の程度を「強」、「中」又は「弱」に判別し、その判別結果を告知するようにする。

【0028】(d)に示すように構成される品質監視装置本体100によって品質監視をすれば、AEセンサ10の信号から直流分を除去され整流された信号の包絡線強度が異常判定基準値を超えた時間を計測し、該時間が所定の時間よりも長い場合に、異常発生旨と包絡線強度が異常判定基準値 $Th1$ を超えた時間に基づく品質異常の程度とが、音声又は表示によって通知される。

【0029】図3は、図2(a)、(b)及び(c)に共通する各処理部の信号波形を概念的に示した図である。図3は、具体的には、図1に示す品質監視構成において、拡張時に接続部31bで品質異常が発生した場合の品質監視装置本体100の各部で出力される波形を示したものであり、(a)はAEセンサ10の出力信号を示し、(b)は絶対値処理部101の出力信号を示し、(c)は比較処理部103の出力信号を示す。

【0030】(a)に示す波形を順に説明する。時刻 $t0$ に拡張マンドレル20の進行によって拡張加工が開始すると、該進行時の拡張マンドレル10と長尺管30との摩擦による振動及び拡張による塑性変形等によって生じるいわゆるアコースティックエミッション(AE)による振動等(以下、これらをまとめて拡張振動という。)が発生する。この拡張振動は品質異常が発生していない場合には、比較的弱い弾性波である。従って、鋼管30aの拡張中である時刻 $t0$ から $t1$ までの時間には、AEセンサ10は比較的小さい振幅の信号波形を出力する。

【0031】次に、接合部31aの拡張をする時刻 $t1$ から $t2$ の時間は、該接合部31aは例えばメカジョイント、拡散接合、溶接等により接合されており、その硬度が鋼管30aよりも高いため拡張マンドレル20の進行が遅くなり、前記拡張振動は、更に弱い振幅の振動となるため、この時間はAEセンサ10は時刻 $t0$ から $t1$ よりも小さい振幅の信号波形を出力する。鋼管30bを拡張する時刻 $t2$ から $t3$ までの時間には、前記時刻 $t0$ から $t1$ までの時間と同様に、AEセンサ10は比較的弱い振幅の信号波形を出力する。

【0032】そして、次の接合部31bの拡張中にひび割れが発生すると、その破壊によりエネルギーが発散され比較的大きな振幅の弾性波が生じる。AEセンサ10は該弾性波を含む拡張振動を検出して、時刻 $t3$ から $t4$ の時間には、比較的大きな振幅の信号波形を出力す

る。以降、図からわかるようにAEセンサ10は、鋼管31cを拡張する時刻t4からt5の時間には比較的小振幅の信号波形を、図示しないその次の接合部を拡張する時刻t5からt6の時間は更に小さい振幅の信号波形を出力する。

【0033】一方、絶対値処理部101の出力波形は、

(a)に示すAEセンサ出力の直流分を除去し絶対値化したものであり、(b)に示す如き波形となる。また、比較処理部103は、前記絶対値処理部101の出力信号を前記のように設定された異常判定基準値TH1と比較して、該基準値TH1よりも大きいときには「Hi」を出力し、該基準値よりも小さいときには「Lo」を出力する。

【0034】従って、比較処理部103は、(b)に示す絶対値処理部101の出力信号が入力されると、

(c)に示す波形を出力する。時刻t0からt3の時間は、絶対値処理部101からは前記異常判定基準値TH1よりも大きな入力がないので出力は「Lo」のみである。次に、前記のように時刻t3からt4の時間にひび割れが発生するので、(b)に示すように、前記異常判定基準値TH1よりも大きな振幅の信号が入力され、

(c)において時刻t3からt4の時間に、パルスP1からP3を出力する。続いて、時刻t4からt6の時間は、前記基準値TH1よりも大きな入力がないので、再び「Lo」のみである。

【0035】図2の(a)ないし(c)の構成を有する品質監視装置本体100の夫々は、これらの図3(a)ないし(c)に示す出力信号に基づいて、次のように処理をする。図2(a)に示す品質監視装置本体100は、比較処理部103から「Hi」のパルスが出力されたので、告知手段110へ異常発生信号を発し、告知手段110が異常の発生を告知する。

【0036】図2(b)に示す品質監視装置本体100は、比較処理部103から出力されるパルスの回数が3回であり、2回以上に該当するので品質異常発生の旨を告知する。また、高値発生信号であるパルスの回数の3回に対応する品質異常の程度を告知するようにしても良い。

【0037】図2(c)に示す品質監視装置本体100においては、ピーク値検出部107は、比較処理部103から「Hi」信号が3回出力されるので、夫々のパルス発生時の絶対値処理部101の出力のピーク値PK1ないしPK3を検出し、告知手段110に異常発生信号及びピーク値PK1ないしPK3を伝える信号を伝送する。告知手段110は、品質異常の発生の旨及び前記ピーク値PK1ないしPK3に対応する品質異常の強弱の程度を、音声あるいは表示により告知する。

【0038】図4は、図2(d)の各処理部の信号波形を概念的に示した図である。図4は、具体的には、図1に示す品質監視構成において、拡張時に接合部31bで

品質異常が発生した場合の品質監視装置本体100の各部で出力される波形を示したものである。(a)はAEセンサ10の出力信号を示し、その波形は図3(a)に等しい。(b)は絶対値処理部101の出力信号を示し、その波形は図3(b)に等しい。(c)は包絡線検波部106の出力波形を示している。

【0039】図2の(d)の構成を有する品質監視装置本体100は、図4に示す信号に基づき、次のように品質異常を検出する。比較処理部103及びパルス幅判定部108により包絡線強度の推移を判定し、該包絡線強度が前記異常判定基準値Th1よりも大きい時間(比較処理部103が前記高値発生信号を出力する時間であり、図においてTで示される。)が所定の時間よりも長い場合に、告知手段110に異常発生信号及び前記時間Tを伝える信号を伝送する。告知手段110は、品質異常の発生の旨及び前記時間Tに対応する品質異常の強弱の程度を、音声あるいは表示により告知する。

【0040】図5は、図2(a)～(d)に示した鋼管品質監視装置以外の処理構成例を示す制御ブロック図である。AEセンサ10は、前記長尺管30に着設され、長尺管30の表面の振動を信号に変換し出力する。絶対値処理部101は、AEセンサ10の出力信号の直流分を除去した信号の絶対値を増幅処理部105及び包絡線検波部106に出力する。

【0041】増幅処理部105は絶対値処理部101の出力を増幅する部分であるが、その際に、AEセンサに届く弾性波の減衰を補正するために、包絡線検波部106の出力に基づいて、該増幅度を任意の時刻tの該包絡線強度 Λ_t に反比例する様にしている。従って、拡張初期の時刻tsの包絡線の強度 Λ_s を基準として、監視時刻tの増幅度は、 Λ_s/Λ_t に設定する。

【0042】包絡線検波部106は、絶対値処理部101の出力信号の各種入値を結ぶ包絡線に所定の処理をした信号を出力し、増幅処理部105に伝送する。ここでは、後に詳述するように、母体となる鋼管30a、30b、30c・・・の拡張時であり異常が発生していない時のAEセンサ出力の振幅を前記増幅度補正の指標とするように、包絡線を処理して増幅処理部105に出力する。

【0043】異常判定基準値設定部102は、増幅処理部105の出力信号の振幅の大きさを判断するための閾値である異常判定基準値Th2を設定する部分である。異常判定基準値設定部102は該長尺管30の拡張加工を始めた初期の時刻tsの包絡線検波部106の出力の振幅 Λ_s に予め設定した係数k2(但し、 $k2 > 1$)を乗じた値を自動的に設定する。

【0044】前記比較処理部103は、増幅処理部105から入力される信号を前記異常判定基準値Th2と比較して、増幅処理部105の信号が異常判定基準値Th2を超えた場合に高値発生信号を出力する。告知手段1

10は、前記高値発生信号が入力されたときに、品質異常が発生した旨を音声或いは表示によって操作者に通知する。

【0045】図6及び図7は、図5に示す各処理構成部の出力を概念的に示した波形図である。具体的には、図1に示す構成で長尺管30の拡張を行なって、接合部32bでひび割れが発生した場合における、図5に示す処理構成の各部の出力波形図である。

【0046】図6(a)に示す信号は、AEセンサ10が長尺管の振動を信号化したものである。この波形は、図3(a)に示す波形と同じであり、全く同様に推移する。即ち、鋼管30aの拡張を行なう時刻t0からt1までは比較的小さい振幅の信号が出力され、接合部31aの拡張をする時刻t1からt2の時間は、時刻t0からt1よりも小さい振幅の信号波形を出力する。

【0047】続いて、鋼管30bの拡張を行なう時刻t2からt3までの時間には、前記時刻t0からt1までの時間と同様に、AEセンサ10は比較的小さい振幅の信号波形を出力し、接合部31bの拡張中でありひび割れが発生する時刻t3からt4の時間には、比較的大きな振幅の信号波形を出力する。以降、鋼管30cの拡張を行なう時刻t4からt5の時間には比較的小さい振幅の信号波形を、図示しないその次の接合部を拡張する時刻t5からt6の時間は更に小さい振幅の信号波形を出力する。

【0048】図6(b)に示す波形は、絶対値処理部101の出力信号であり、AEセンサ10の出力信号の直流分を除去した信号を絶対値化したものである。図6(c)に実線で示す波形は、包絡線検波部106の出力信号であり、絶対値処理部101の出力の包絡線を次のように処理したものである。

【0049】即ち、時刻t1から時刻t2、時刻t3から時刻t4及び時刻t5からt6の時間は、長尺管の接続部31a、31b、31c・・・の拡張を行なっている時間又は異常が発生している時間の該包絡線は図6

(c)に破線で示す波形になるが、これらの時間については該破線で示す波形を出力せず、その前、後又は前後の時間の包絡線強度の変化から補間した値(図中実線で示す)を該当該時刻の包絡線強度A_tとして出力することにする。

【0050】例えば、前記基準の包絡線の推移から求めた予測値と実際の計測値との差又は比が所定の範囲を超えた場合には、該実測値の代わりに該予測値をもちいるようにすればよい。このようにすれば、接続部の拡張時及び品質異常発生時の包絡線強度は母体の鋼管の拡張時の包絡線強度の推移から予測される値を大きく外れるので、これらの時刻の包絡線強度の代わりに前記予測値が使用される。

【0051】図7(a)は、増幅処理部105の出力信号である。この出力は、増幅処理部105が、AEセン

サに届く弾性波の減衰を補正するために、図6(c)に実線で示す包絡線検波部出力の強度に反比例する増幅度で、絶対値処理部101が出力する図6(b)に示す信号を増幅した結果である。図からもわかるように、増幅処理部105は絶対値処理部101の信号を増幅する度合を、拡張中の部位からAEセンサの距離が離れるに応じて高め、拡張による弾性波の減衰を適確に補正して出力する。

【0052】図7(b)は比較処理部103の出力信号を示す。比較処理部103は増幅処理部の出力が前記異常判定基準値Th2を超えると「Hi」信号を出力するので、時刻t3から時刻t4の時間に、高値発生信号であるパルス信号P1乃至P3を出力する。告知手段110は、該高値発生信号を受けて、品質異常の発生を音声又は表示により通知する。

【0053】更に、前記比較回路部103と前記告知手段110との間に、パルス計数処理部を設け、比較処理部103からの前記高値発生信号の回数を計数し、その回数を告知手段110に伝え、告知手段110は品質異常発生の際及び高値発生信号の回数に応じた品質異常の程度を告知するようにしてもよい。

【0054】一方、前記比較回路103からの高値発生信号が出力されたときに、その直後の増幅回路出力の極大値を検出し、その値を告知手段に伝えるピーク値検出部を設け、告知手段110は品質異常発生の際及び該ピーク値の大きさに応じた品質異常の程度を告知するようにしてもよい。

【0055】図8は、鋼管を実際に拡張してひび割れが発生したときの各処理部の出力波形図である。具体的には、図1及び図2(a)に記載の構成によって、本発明による品質監視を実際に行なった場合の出力波形図である。(a)において、時刻t1前後、時刻t2前後、時刻t3前後に発生する大きな振幅の出力波形は、これらの時刻に、ひび割れが発生したために生じたものである。

【0056】図からもわかるように、前記異常判定基準値設定部102が、前記異常判定基準値Th1を拡張初期の時刻tsにおけるAEセンサの振幅Asの5倍の値に設定すると、比較処理部103は(b)に示すように前記高値発生信号であるパルス信号を時刻t1付近に1回、時刻t2付近に2回、時刻t3に3回発生する。従って、告知手段110は、これらの時刻t1、t2又はt3に異常発生の際を告知する。

【0057】本発明は、前記した実施の形態に何ら限定されるものではなく、本発明の趣旨を逸脱しない範囲で種々の改変が可能である。例えば、監視対象となる鋼管は接合部を有するものに限られないことは、言うまでもない。AEセンサの取付位置は鋼管の側面に限られず、端面に取り付けてもよい。また、前記実施の形態では、拡張マンドレルをテーパ部分を有する拡張マンドレルと

したが、これに限られるわけではなく、例えば、マンドレルの外側面に拡張ローラを有し、該拡張ローラにより鋼管内壁を半径方向外方に押し広げて拡張を行なう構成の拡張マンドレルとしても良い。

【0058】一方、前記異常判定基準値の設定についても実施の形態で例示した処理に限られず、異常なく拡張が行なわれている時の判定対象となる信号の振幅と品質異常が発生した時の判定対象となる信号の振幅との間の値になるように設定すればよい。更に、前記実施の形態において、アナログ信号処理により行なっている処理を、デジタル信号処理により行なうようにしてもよい。例えば、絶対値処理部101或いは増幅処理部105の後にA/Dコンバータを設けてその出力をデジタル信号に変換し、以降の処理をデジタル信号処理により行なうようにしてもよい。

【0059】

【発明の効果】本発明の請求項1に記載の拡張時の品質監視方法によれば、拡張マンドレルが移動して拡張をするときには、常に拡張部位で振動が発生しており、鋼管に品質異常が発生した際には、AEセンサ信号振幅がその前後の時刻の振幅よりも大きくなることを利用したものであり、品質監視のために特別に励振装置、照射装置等を設けることなく拡張時の品質異常の発生を判定することが可能であるという効果を有する。

【0060】また、かかる拡張装置が移動及び拡張するときに発生する振動は、拡張している部位から離れた位置にあるAEセンサまで鋼管を伝搬して届くので、監視装置全体が一定の場所に静止した状態で拡張時の品質監視を行なうことが可能であり、かつ、長尺の鋼管の拡張時の品質監視が可能であるという効果を有する。更に、該振動が伝搬する速度は非常に速いので、拡張によって例えばひび割れ等の品質異常が発生したときには、発生とほぼ同時に品質異常の発生又はその品質異常の程度を検出することが可能である。

【0061】更に、請求項2に記載の拡張時の品質監視方法によれば、請求項1に記載の品質監視方法の効果に加えて、品質監視のために特別に励振装置、照射装置等を設ける必要がなく、監視装置全体が一定の場所に静止した状態で、品質異常の発生とほぼ同時に、品質異常の程度を判定することができるという効果を奏する。

【0062】また、請求項3に示す拡張時の品質監視方法によれば、AEセンサ信号の振幅の連続的な減少に応じてAEセンサの増幅の度合を高め、AEセンサの振幅の連続的な増加に応じてAEセンサ信号の増幅の度合を低下させるようにしたので、拡張によって生じる弾性波がAEセンサに届くまでの減衰を高い精度で補正することができ、該AEセンサ信号を用いて行なう処理の確実性及び信頼性を高めることができるという効果を有する。

【0063】例えば、拡張マンドレルがAEセンサから

離れている場合にはAEセンサ信号の低下が補正されるので、より長尺の鋼管においても確実性の高い品質異常の発生判定及び品質異常の程度の判定が可能になる。また、伝搬距離の変動によるAEセンサ信号振幅の変動が小さくなり、品質異常の発生判定及び品質異常の程度の判定の感度が安定するので、これらの判定の信頼性を高めた拡張時の品質監視方法が提供されることになる。

【図面の簡単な説明】

【図1】本発明に係る鋼管の拡張時の品質監視方法の概念を説明するために示した概略構成図である。

【図2】本発明に適用される鋼管品質監視装置の信号処理構成例を示す制御ブロック図である。

【図3】図2(a)、(b)及び(c)に共通する各処理部の信号波形を概念的に示した図であり、(a)はAEセンサの出力信号、(b)は絶対値処理部の出力信号、(c)は比較処理部の出力信号を示す波形図である。

【図4】図2(d)の各処理部の信号波形を概念的に示した図であり、(a)はAEセンサの出力信号、(b)は絶対値処理部の出力信号、(c)は包絡線検波部の出力信号を示す波形図である。

【図5】図2(a)～(d)に示した鋼管品質監視装置以外の処理構成例を示す制御ブロック図である。

【図6】図5に示す鋼管品質監視装置における各処理構成部の出力を概念的に示した波形図であり、(a)はAEセンサの出力信号、(b)は絶対値処理部の出力信号、(c)は包絡線検波部の出力信号を示す波形図である。

【図7】図5に示す鋼管品質監視装置における各処理構成部の出力を概念的に示した波形図であり、(a)は増幅処理部の出力信号、(b)は比較処理部の出力信号を示す波形図である。

【図8】鋼管を実際に拡張してひび割れが発生したときの各処理部の出力波形図であり、(a)は絶対値処理部の出力波形図、(b)は比較処理部の出力波形図である。

【符号の説明】

- 10 AEセンサ
- 20 拡張マンドレル
- 30 長尺管
- 30a、30b、30c、・・・ 鋼管
- 31a、31b、・・・ 接合部
- 100 品質監視装置本体
- 101 絶対値処理部
- 102 異常判定基準値設定部
- 103 比較処理部
- 104 バルス計数部
- 105 増幅処理部
- 106 包絡線検波部

107 ピーク検出部
108 パルス幅判定部

110 告知手段

【図1】

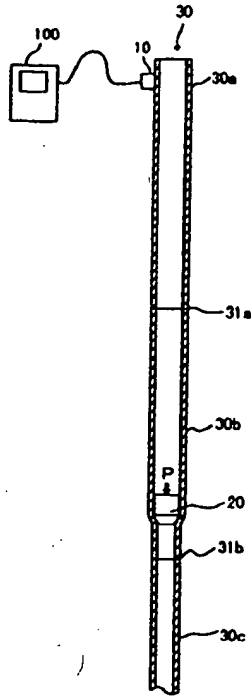

【図3】

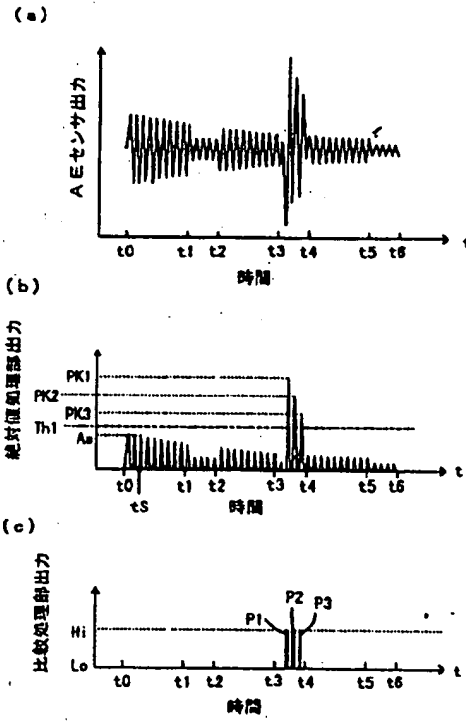

【図5】

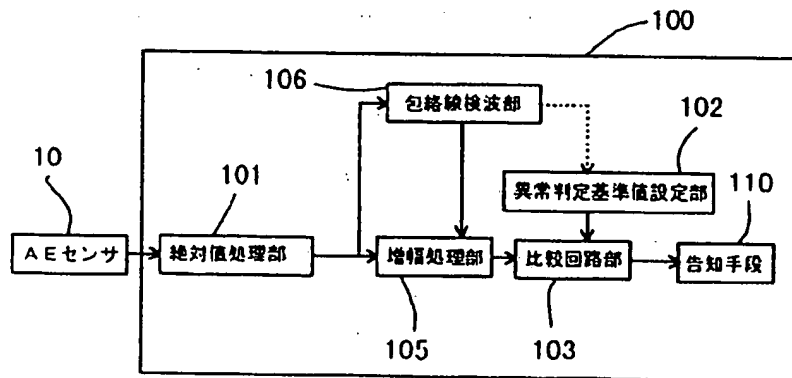

【図2】

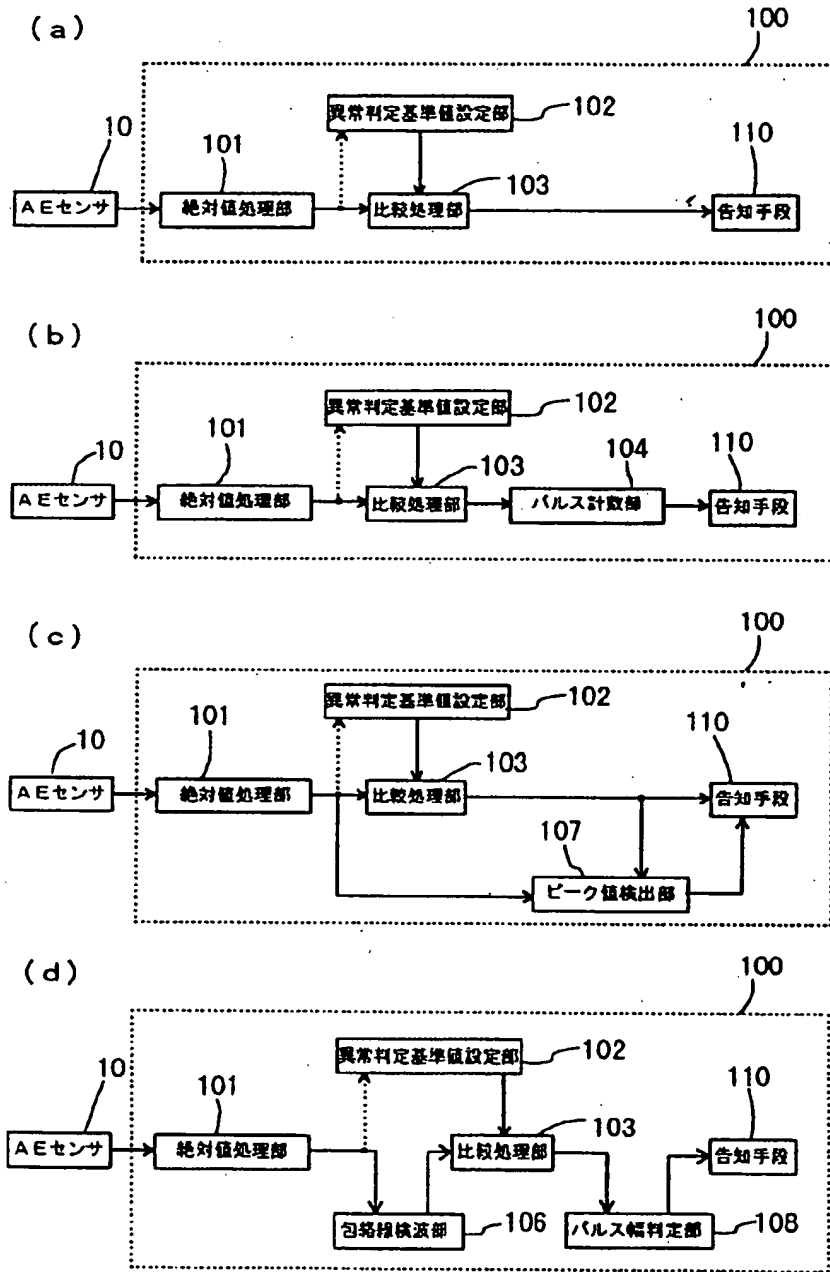

【図4】

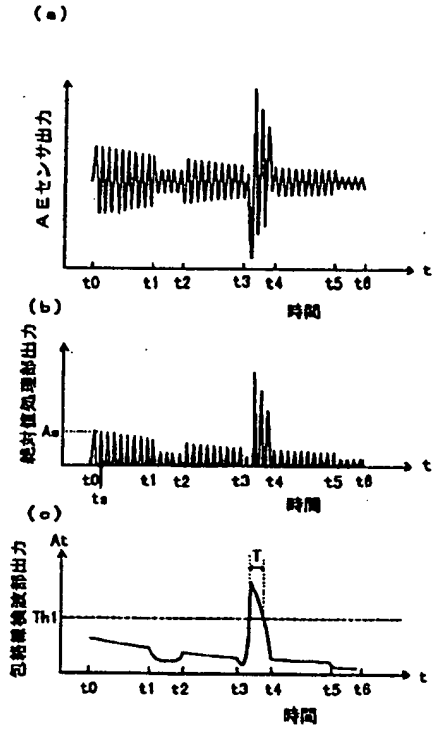

【図6】

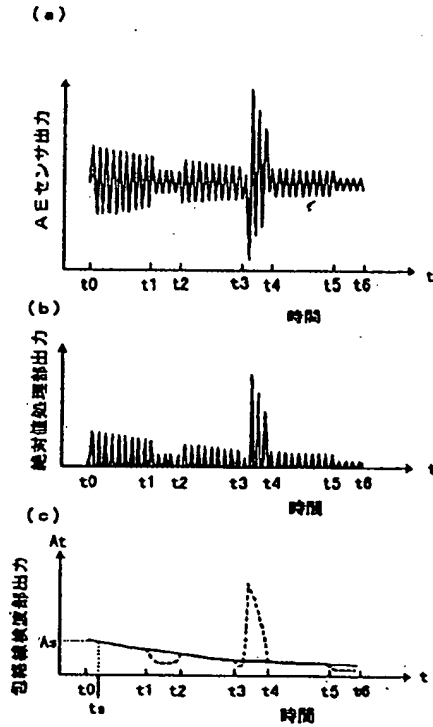

【図7】

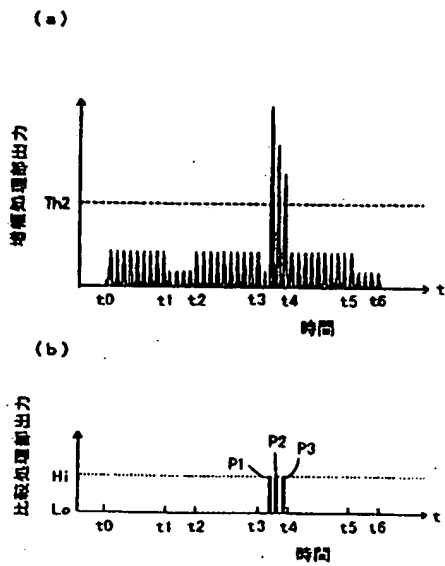

【図8】

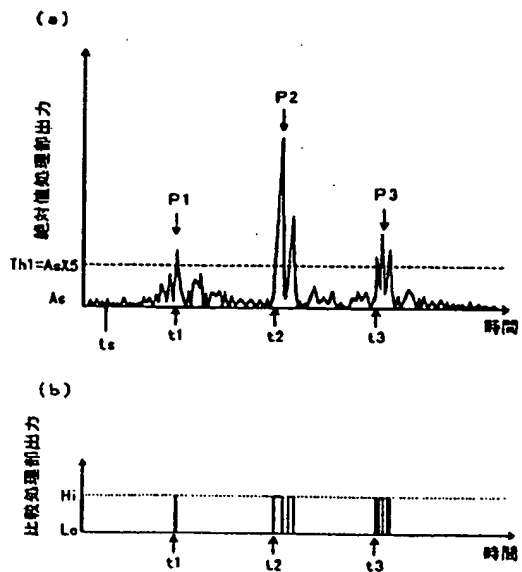

フロントページの続き

ドクーム(参考) 2G047 AA07 AB01 AD08 BA05 BC00
BC03 BC07 EA10 EA11 GF06
GF10 GG06 GG09 GG24 GG30
GG33 GG41
2G064 AA04 AB02 AB05 AB08 CC16
CC22 CC26 CC28 CC46 CC54
2G067 AA12 DD13 DD27

(19) Japan Patent Office (JP)
(12) Japanese Unexamined Patent Application Publication (A)
(11) Japanese Unexamined Patent Application Publication 2000-162192
(P2000-162192A)
(43) Disclosure Date: June 16, 2000

(51)	Int. Cl. ⁷	Classification Symbols:	FI:	Theme Codes (Reference)
	G01N 29/14		G01N 29/14	2G047
	G01H 11/06		G01H 11/06	2G064
	G01M 3/02		G01M 3/02	G 2G067
	3/24		3/24	A

Request for Examination: Not Yet Submitted
Number of Claims: 3
OL
(Total of 11 pages)

(21) Japanese Patent Application: H10-336745
(22) Filing Date: November 27, 1998

(71) Applicant: Daido Steel Co., Ltd. (000003713)
1-11-18 Nishiki, Naka-ku, Nagoya, Aichi Prefecture
(72) Inventor: Ryuzo Yamada
48-1 Nishikatada, Okusa, Chita, Aichi Prefecture
(72) Inventor: Koji Horio
18 Minamishikamochi, Kagiya-machi, Tokai, Aichi Prefecture
(72) Inventor: Takao Hiyamizu
Yagoto San Haitsu 501
2-311 Omoteyama, Tenpaku-ku, Nagoya, Aichi Prefecture
(74) Agent: Noboru Ueno, Patent Attorney (100095669) (and 1 other)

Continued on last page

(54) {Title of the Invention} Quality Inspection Method for Use During Tube Expansion

(57) {Summary}

{Problem}

To offer a quality inspection method for expanded tubes whereby the occurrence of quality aberration or the degree of quality aberration can be determined at the time of expansion of the steel tube, and whereby remote observation is possible.

{Solution} An AE sensor 10, which detects steel tube vibrations during tube expansion occurring as a tube expansion mandrel 20 moves through the interior of a steel tube 30, is situated against the steel tube. Increases in the AE sensor signal amplitude, the number of increases in the AE sensor signal amplitude or the time over which the increase in AE sensor signal amplitude occurs is detected, and the occurrence of quality aberration or the degree of quality aberration in the aforementioned steel tube is determined on the basis of the detected signals.

[see source for diagram]

{Scope of Patent Claims}

{Claim 1} A quality inspection method for use during tube expansion, characterized in that an AE sensor for detecting vibrations in a steel tube during tube expansion of said steel tube is situated against the steel tube, and when tube expansion occurs as a tube expansion mandrel moves through the interior of the steel tube, increases in the AE sensor signal amplitude, the number of increases in the AE sensor signal amplitude or the time over which the increase in AE sensor signal amplitude occurs is detected, and the occurrence of quality aberration in the aforementioned steel tube is determined on the basis of the detected signals.

{Claim 2} The quality inspection method for use during tube expansion according to Claim 1, characterized in that the degree of the quality aberration in the steel tube is determined based on the magnitude of the AE sensor signal amplitude, the number of increases in AE sensor signal amplitude or the time of increase in AE sensor signal amplitude.

{Claim 3} The quality inspection method for use during tube expansion described in Claim 1 or 2, characterized in that the AE sensor signal that is detected during tube expansion is amplified as a tube expansion mandrel moves through the interior of a steel tube, and the level of the aforementioned amplification is increased in accordance with a continual decrease in AE sensor signal amplitude, or the level of the aforementioned amplification is decreased in accordance with a continual increase in AE sensor amplitude.

{Detailed Description of the Invention}

{0001}

{Technological Field of the Invention} The present invention relates to a quality inspection method used during tube expansion. In particular, the invention is a quality inspection method used during tube expansion that is appropriate for inspecting quality aberrations such as cracking or pinholes generated in the joints of long steel tubes, etc., during the expansion of steel tubes.

{0002}

{Prior Art} In the past, the tube expansion of long tubes formed from steel has been carried out using tube expansion mandrels. As shown in Figure 1, this process involves the insertion of a tube expansion mandrel 20 into one of the open ends of a long tube 30, applying a specified weight P in order to insert the tube expansion mandrel 20 into the long tube 30, and pushing the mandrel across the inner wall of the long tube 30 towards the other end, thus performing tube expansion.

{0003} However, there are cases where quality aberrations such as cracks are produced in steel tubes during the tube expansion process. In particular, with tube expansion in steel tubes having mechanical joints or welded regions produced by welding or diffusion welding, quality aberrations readily occur in welded regions. In order to detect these quality aberrations, non-destructive inspections have been traditionally carried out. For example, ultrasonic defect diagnostic methods have been used wherein ultrasound is made to impinge upon the body to be inspected, and internal defects are found based on differences in reflected waves at end surfaces and defect surfaces. In addition, x-ray defect diagnostic methods have been used in which x-rays are made to impinge upon the body to be inspected, and the transmitted radiation is then used to sensitize film, so that the defects can be detected from the photosensitive image thereupon.

{0004} However, in carrying out these inspection methods, there is the problem that at least part of the detection device must be positioned in the region that is to be inspected, and this creates problems that are exacerbated as the length of the tube increases. In addition, there is the problem these inspection methods cannot be carried out on-site during the tube expansion operation, so they must be carried out after completion of tube expansion, at least in the region that is to be inspected. Specifically, with conventional inspection methods, inspection must be carried out with at least part of the inspection device located in the region to be inspected after completion of tube expansion.

{0005} On the other hand, when installing oil well pipes for drawing oil, etc., out of the ground, technologies are known in which tube expansion is carried out by inserting a steel tube with a comparatively small diameter into the ground, and then inserting a tube expansion mandrel, etc., using high downward compressive force, which thereby reduces equipment installation costs. In order to

inspect expanded steel tubes using this conventional method, it is difficult to situate the inspection device at the outer wall surface of the steel tube, and is also difficult to move the inspection device in the lengthwise direction along the outer wall of the steel tube because the tube has been laid underground. Consequently, it has been necessary to inspect the tube by moving the inspection device long the interior of the steel tube. However, the tube diameter is small even after tube expansion, and the total length of the tube can be as long as several kilometers, so there have been extremely difficult problems with quality aberration inspection over the entire length of a steel tube using conventional methods.

{0006}

{Problems to be Solved by the Invention} The problem to be solved by the present invention is that of offering a quality inspection method used at the time of tube expansion, whereby quality aberrations in steel tubes can be evaluated with the inspection device in a stationary condition during the tube expansion process for the steel tube, whereby an occurrence or degree of quality aberration can be determined at a site that is removed from the quality inspection device, and whereby quality aberrations in said steel tube can be detected almost simultaneous to their occurrence.

{0007}

{Means for Solving the Problems} The gist of the present invention used in order to solve these problems relates to a quality inspection method used during tube expansion wherein an AE sensor for detecting vibrations in a steel tube during tube expansion of said steel tube is situated against the steel tube, and when tube expansion occurs as a tube expansion mandrel moves through the interior of the steel tube, increases in the AE sensor signal amplitude, the number of increases in the AE sensor signal amplitude, or the time over which the increase in AE sensor signal amplitude occurs is detected, and the occurrence of quality aberration in the aforementioned steel tube is determined on the basis of the detected signals.

{0008} By means of the quality inspection method used during tube expansion pertaining to the present invention carried out in this manner, vibrations arising on the interior of a steel tube and on the surface of a steel tube during tube expansion occurring as a tube expansion mandrel passes through the interior of a steel tube are detected by an AE sensor situated on the steel tube, and quality aberration is judged to have occurred when an increase amplitude of the aforementioned AE sensor signal is detected, when the number of increases in amplitude of the aforementioned AE sensor signal reaches a predetermined number, or when the time over which the increase in amplitude of the aforementioned AE sensor signal occurs is longer than a predetermined time.

{0009} In addition, as with the invention described in Claim 2, when the degree of quality aberration of the aforementioned steel tube is to be judged based on the magnitude of the increase in AE sensor signal amplitude, the number of increases of AE sensor signal amplitude, or the time of the increase in AE sensor signal amplitude, detected at the time when the aforementioned quality aberration is determined, the degree of the quality aberration of the aforementioned steel tube can be determined based on the magnitude of the aforementioned AE sensor signal amplitude, the number of increases in the aforementioned AE sensor signal amplitude, or time over which the amplitude of the AE sensor signal has increased.

{0010} In addition, as pertains to the invention of Claim 3, the AE sensor signal detected during tube expansion is amplified at the time of tube expansion as the tube expansion mandrel moves long the interior of the steel tube, and the degree of the aforementioned amplification is increased along with a continual decrease in AE sensor signal amplitude, or the degree of the aforementioned amplification is decreased in accordance with a continual increase in AE sensor amplitude.

{0011} With the quality inspection method used during tube expansion described in Claim 3 of the present invention carried out in this manner, the AE sensor signal detected during tube expansion as the tube expansion mandrel moves along the interior of the steel tube is amplified, and as the damping of vibrations generated by the tube as they are conducted to the AE sensor increases, the degree of the aforementioned amplification is increased, or as the aforementioned damping decreases, the degree of the aforementioned amplification is decreased. By this means, damping occurring with transmission of the vibrations generated by tube expansion to the AE sensor is compensated for, and quality inspection is carried out based on said corrected AE sensor signal.

{0012} Employing the change in degree of amplification in accordance with a continual increase or continual decrease in output amplitude from the AE sensor means that the change in tube expansion amplitude in a region in which the output amplitude of the relatively stable AE sensor changes continually is taken as a reference. For example, this means that the aforementioned amplification level is not made to follow discontinuous change in amplitude, as with changes in AE sensor signal amplitude produced during the occurrence of aberration. By excluding these regions of discontinuous change in this manner, correction is carried out based on the change in AE sensor signal amplitude, so that even if the AE signal amplitude increases or decreases over time during the observation period over which quality aberrations, etc. are generated, the attenuation can be appropriately corrected for without erroneous correction.

{0013}

{Embodiments of the Invention} Desirable embodiments of the present invention are described in detail below in reference to the figures. Figure 1 is a schematic constitutional diagram used for schematically presenting the quality inspection method used during tube expansion of steel tubes pertaining to the present invention. A long tube 30 is shown in cross section. Said long tube 30 is a tube produced by welding relatively short steel tubes 30a, 30b, 30c... at weld regions 31a, 31b... In the figure, only three steel tubes are shown, but these tubes continue downwards.

{0014} The tube expansion mandrel 20 has a cylindrical part and a tapered part as shown in the figures, and a load P is applied from behind (upwards in the figure). As the mandrel travels forward (downwards in the figure), the interior wall of the long tube is pressed outwards in a radial direction due to the aforementioned tapered part, thus expanding the aforementioned long tube 30. The AE sensor 10 is situated in contact with the outer wall of the long tube, and the vibrations at said outer surface are converted into signals as the aforementioned tube expansion is taking place. Said signals are output to an inspection device main unit 100 to which it is connected.

{0015} Figure 2 is a control block diagram showing an example of the signal processing structure in the quality inspection device implemented in the present invention. In the quality inspection device main unit 100 shown in (a), the AE sensor 10 is connected to an absolute value processor 101, and the absolute value processor 101 is connected to a comparative processor 103. An aberration decision standard value setting part 102 is also connected with the comparative processor 103, and the comparative processor 103 is connected to a notification means 110.

{0016} The aforementioned absolute value processor 101 removes the direct current component of the output signal from the AE sensor 10, and outputs signals that have been converted into absolute values. The aforementioned aberration decision standard value setting part 102 is the part where the aberration decision standard value Th1 is set, which is the threshold value for determining the size of the signal amplitude from the AE sensor 10. The aberration decision standard value Th1 should be set at a value that is between the AE sensor signal amplitude when tube expansion is occurring without aberration, and the AE sensor signal amplitude when quality aberrations occur.

{0017} For example, the operator uses a standard value setting knob that is provided in order to set the aberration decision standard value obtained experimentally beforehand in accordance with the type of steel tube that is the subject of tube expansion. In this case, the value is automatically set to a value determined by multiplying the AE sensor signal amplitude A_s at time t_s in the initial stage in which the tube expansion process is initially occurring in said long tube 30 by a constant k_1 that has been determined beforehand (where $k_1 > 1$).

{0018} The aforementioned comparative processor 103 compares the signal input from the absolute value processor 101 with the aforementioned aberration decision standard value Th1, and when the signal from the absolute value processor 101 exceeds the aberration decision standard value Th1, a high-value generation signal is output. When the aforementioned high value generation signal is input into the notification means 110, a quality aberration is judged to have occurred, and an indication of this occurrence is sent to the operator by a tone or display.

{0019} In this manner, when quality inspection is to be carried out by the quality inspection device main unit 100 constituted in the manner shown in (a), the direct current component is taken from the signal from the AE sensor 10, and is rectified to obtain an amplitude. When the signal amplitude from

the AE sensor 10 exceeds the aberration decision standard value, a notification is made regarding the occurrence of aberration.

{0020} The quality inspection device unit 100 shown in (b), as can be seen from the figure, has a pulse counting processor 104 between the notification means 110 and the comparative processor 103 constituting the quality inspection device shown in (a) above. The pulse counting processor 104 is connected to the comparative processor 103 and the notification means 110. The number of the aforementioned high value generation signals received from the comparative processor 103 is calculated, and when this number reaches or surpasses the number that has been previously set, a quality aberration occurrence signal is output. In this case, a quality aberration occurrence signal is output when the number of occurrences of high value generation signals is 2 or greater.

{0021} Consequently, when quality inspection is carried out with a quality inspection device unit 100 constituted as indicated in (b), the signal from the AE sensor 10 is removed and rectified, and its amplitude is obtained. When the signal amplitude from the AE sensor 10 exceeds the aberration decision standard value two or more times, notification of an occurrence of quality aberration is made.

{0022} In addition, in this case, the pulse counting processor 104 transmits the number of high value generation signals to the notification means 110 in addition to the aforementioned quality aberration generation signal. The notification means 110 should be constituted in such a manner that notification is made regarding the occurrence of quality aberration, and the degree of quality aberration in accordance with the number of high value generation signals. For example, the device may be constituted so that the number of high value generations itself is made known, but in this case, notification indicating "slight" in regard to the degree of aberration is made when the number is 2 or 3, notification indicating "moderate" is made when the number is 4 or 5, and notification indicating "high" is made when the number is 6 or greater.

{0023} The quality inspection device unit 100 shown in (c) is expanded upon by adding a peak detector 107 to the quality inspection device presented in (a). Output from the absolute value processor 101 and output from the comparative processor 103 is input into the peak value detector 107, and this is linked to the notification means 110. When the aforementioned high value generation signal is output from the aforementioned comparative processor 103, the peak value detector 107 retains the peak value of the output of the absolute value processor 101 at this time, and outputs this value to the aforementioned notification means 110.

{0024} Thus, the notification means 110 reports the degree of quality aberration based on the aforementioned peak value in addition to reporting the occurrence of quality aberration. For example, the magnitude of the peak value itself may be reported, but in this case, notification of a "high", "moderate" or "low" determination is made in regard to the degree of aberration based on the magnitude of the peak value.

{0025} When quality inspection is carried out using the quality inspection device unit 100 constituted as indicated in (c), the signal from the AE sensor 10 is rectified after removing the direct current component, and the amplitude is obtained. When the signal amplitude of the AE sensor 10 exceeds the aberration decision standard value Th_1 , sound or display is used in order to present an indication of an occurrence of aberration and the degree of quality aberration based on the peak value of the AE sensor signal amplitude at the time of occurrence of said quality aberration.

{0026} The quality inspection device unit 100 shown in (d) is a unit in which an envelope detector 106 is also included between the absolute value processor 101 and the comparative processor 103 in the quality inspection device presented in (a), and a pulse width discriminator 108 is also provided between the comparative processor 103 and the notification means 110. The aforementioned envelope detector 106 outputs an envelope signal linking each of the maximum values of the output signals of the absolute value processor 101, and this is transmitted to the comparative processor 103. The comparative processor 103 outputs a high value generation signal to the notification means 110 when the output of the envelope detector 106 is larger than the aforementioned aberration decision standard value Th_1 . The pulse width discriminator 108 transmits an indication of an aberration occurrence and the length of time for the aforementioned high value generation to the notification means 110 when the time of the aforementioned high value generation signal is longer than a determined time period.

{0027} Thus, the notification means 110 performs notification of a quality aberration occurrence and degree of quality aberration based on the length of the aforementioned high value generation signal. For example, notification may be made as to the length of the aforementioned high value generation signal itself, but in this case, notification is made as to the results of determination based on "high", "moderate" or "low" in regard to the degree of aberration determined based on the length of the aforementioned high value generation signal period.

{0028} When quality inspection is carried out with the quality inspection device unit 100 constituted as shown in (d), the direct current component is removed from the AE sensor 100 signal, and the time for which the envelope intensity of the rectified signal exceeds the aberration decision standard value is calculated. If said time is longer than the determined time period, then sound or display is used in order to make a notification regarding quality aberration and the degree of quality aberration determined based on the time that the envelope intensity exceeded the aberration decision standard value TH1.

{0029} Figure 3 presents a schematic diagram in which the signal waveform for each of the processors is shown in common for Figure 2a, 2b and 2c. Specifically, Figure 3 shows the waveform outputs at each part of the quality inspection device unit 100 when a quality aberration has occurred at the connection 31b during tube expansion, for the quality inspection system shown in Figure 1, whereas (a) shows the output signal for the AE sensor 10, (b) shows the output signal for the absolute value processor 101, and (c) shows the output value for the comparative processor 103.

{0030} The waveform shown in (a) will be described in sequence. When the tube expansion process is initiated with advancement of the tube expansion mandrel 20 at time t_0 , vibrations are generated via acoustic emission (AE) arising due to plastic deformation, etc., occurring with tube expansion and vibrations are generated due to friction between the long tube 30 and the tube expansion mandrel 10 as advancement occurs (these vibrations are referred to in combination as "tube expansion vibrations"). When there is no aberration in quality, the tube expansion vibrations give a comparatively weak elastic wave. Consequently, for the period extending from time t_0 to time t_1 during tube expansion of the steel tube 30a, a signal waveform having a comparatively small amplitude is output by the AE sensor 10.

{0031} Next, during the period from time t_1 to time t_2 in which tube expansion of the weld 31a occurs, said weld region 31a has been welded by mechanical joining, diffusion welding or welding, so its hardness is higher than that of the steel tube 30a. As a result, the progress of the tube expansion mandrel 20 slows, and the aforementioned tube expansion vibrations give vibrations of even weaker amplitude. At this time, the AE sensor 10 outputs a signal waveform for vibrations that are smaller from time t_0 to time t_1 . During the time from t_2 to t_3 in which the steel tube 30b expands, the AE sensor 10 outputs a signal waveform with a comparatively weak amplitude as with the time period from time t_0 to t_1 described above.

{0032} When there is a crack generated during tube expansion of the connection 31b, the energy emanates from the crack, and an elastic wave with a comparatively large amplitude is produced. The tube expansion vibrations that include said elastic waves are detected by the AE sensor 10, and during the period from time t_3 to time t_4 , a signal waveform with a comparatively large amplitude is output. Subsequently, as shown in the figure, the AE sensor 10 outputs a signal waveform that has a comparatively small amplitude from time t_4 to time t_5 during tube expansion of the steel tube 31c as shown in the figure. Then a signal waveform with an even smaller amplitude is output from time t_5 to time t_6 during expansion of the next weld region thereof not shown in the figure.

{0033} Meanwhile, the output waveform from the absolute value processor 101 is the absolute value conversion determined after removing the direct current component of the AE sensor output shown in (a), thus producing the waveform shown in (b). In addition, the comparative processor 103 compares the output signal from the aforementioned absolute value processor 101 with the aberration decision standard value TH1 set as described above, and a "Hi" signal is output when the value is larger than said standard value TH1, whereas a "Lo" signal is output when said value is smaller than said standard value.

{0034} Consequently, when the output signal of the absolute value processor 101 shown in (b) is input, the comparative processor 103 outputs the waveform shown in (c). During the time from time t_0

to time t_3 , the output remains "Lo" because there is no input from the absolute value processor 101 that is higher than the aforementioned aberration decision standard value TH1. Next, because a crack is generated in the time period from time t_3 to t_4 , a signal having an amplitude that is larger than the aforementioned aberration decision standard value TH1, as shown in (b) is input, and pulses P1 to P3 are output during the time period from time t_3 to t_4 in (c). Subsequently, there is no output that is larger than the aforementioned standard value TH1 during the time period from time t_4 to t_6 , and so the value remains "Lo".

{0035} With the respective quality inspection device units 100 having the constitutions described in (a)-(c) of Figure 2, the following types of processes are carried out based on the output signals shown in (a)-(c) of Figure 3. With the quality inspection device unit 100 shown in Figure 2(a), a "Hi" pulse is output from the comparative processor 103, and an aberration generation signal is output to the notification device 110, so that notification of an occurrence of an aberration is made by the notification means 110.

{0036} With the quality inspection device unit 100 shown in Figure 2(b), the number of pulses output from the comparative processor 103 is 3, and because this corresponds to 2 or more occurrences, notification is made regarding an indication of quality aberration. In addition, notification is also made regarding the degree of quality aberration corresponding to a pulse number of three for the high value signals.

{0037} In the quality inspection device unit 100 shown in Figure 2(c), the peak value detector 107 produces three outputs of "Hi" signals from the comparative processor 103, and so peak values PK1 through PK3 of the absolute value processor 101 output are detected during the pulse generation time. Consequently, an aberration occurrence signal and signals representing the peak values PK1 to PK3 are sent to the notification means 110. The notification means 110 then makes notification, via sound or display, of the occurrence of quality aberration, and the degree of the quality aberration corresponding to the aforementioned peak values PK1 through PK3.

{0038} Figure 4 is a diagram that presents a schematic representation of the signal waveforms for each of the processors in Figure 2(d). Figure 4, specifically, represents the waveform output at each of the parts of the quality inspection device unit 100 when there is a quality aberration at the connection 31b during tube expansion carried out by the quality inspection system presented in Figure 1, whereas (a) represents the output signal of the AE sensor 10, where this waveform is similar to that of Figure 3(a). Here, (b) represents the output signal of the absolute value processor 101, where this waveform is similar to that of Figure 3(b), and (c) represents the output waveform of the envelope detector 106.

{0039} The quality inspection device unit 100 having the constitution of (d) in Figure 2 detects quality aberration in the following manner based on the signals presented in Figure 4. The variation in envelope intensity is determined by the pulse width determination part 108 and the comparative processor 103, and when the time during which said envelope intensity is greater than the aforementioned aberration decision standard value Th1 (time over which the comparative processor 103 outputs the aforementioned high value generation signal; represented by T in the figure) is longer than the predetermined time, an aberration generation signal and a signal that transmits the aforementioned time T is sent to the notification means 110. The notification means 110 then makes a notification, via sound or display, as to the occurrence of quality aberration, and the degree of quality aberration corresponding to the aforementioned time period T.

{0040} Figure 5 is a control block diagram showing a processing system example that is different from the steel tube quality inspection device presented in Figures 2(a)-(d). The AE sensor 10 is attached to the aforementioned long tube 30, and surface vibrations from the long tube 30 are converted to signals that are output. The absolute value processor 101 removes the direct current component of the AE sensor 10 output signal, and outputs the absolute value of the resulting signal to the amplification processor 105 and envelope detector 106.

{0041} The amplification processor 105 is the part that amplifies the absolute value processor 101 output, and in order to correct for attenuation of the elastic waves reaching the AE sensor at this time, said level of amplification is made such that it is inversely proportional to said envelope intensity at any given time t, based on the output of the envelope detector 106. Consequently, the level of

amplification at inspection time t_s is set at A_s/A_t using, as reference, the intensity A_s of the envelope at time t_s during the initial tube expansion period.

{0042} The envelope detector 106 outputs a signal produced by carrying out specified processing on the envelope that links each maximum of the output signals from the absolute value processor 101, and this signal is transmitted to the amplification processor 105. As described in detail below, when no aberrations are being generated during tube expansion of the main steel tube bodies 30a, 30b, 30c..., the envelope is processed taking the amplitude of the AE sensor output as an index of the aforementioned amplification level correction. The result is output to the amplification processor 105.

{0043} The aberration decision standard value setting part 102 is the part whereby the aberration decision standard value Th_2 is set, which is the threshold value for determining the magnitude of the output signal amplitudes from the amplification processor 105. The aberration decision standard value setting part 102 automatically is set to a value found by multiplying the amplitude A_s of the output from the envelope detector 106 at time t_s during the initial period of the tube expansion process of said long tube 30 by a predetermined constant k_2 (where $k_2 > 1$).

{0044} The aforementioned comparative processor 103 compares the signal input from the amplification processor 105 with the aforementioned aberration decision standard value Th_2 , and outputs a high value generation signal when the signal of the amplification processor 105 is greater than the aberration decision standard value Th_2 . The notification means 110 notifies the operator via sound or display as to the occurrence of quality aberration when the aforementioned high value generation signal has been input.

{0045} Figure 6 and Figure 7 are waveform diagrams that give a schematic presentation of the outputs of each of the constitutive processors shown in Figure 5. Specifically, the figures are output waveform diagrams for each of the constitutive processors shown in Figure 5 when cracks occur in the connection 32b along with tube expansion of a long tube 30 having the constitution shown in Figure 1.

{0046} The signal shown in Figure 6(a) is produced by conversion of the vibrations from the long tube into signals by the AE sensor 10. This waveform is the same as the waveform shown in Figure 3(a) and varies similarly. Specifically, an amplitude signal that is comparatively small is output from time t_0 to time t_1 as tube expansion of the steel tube 30a is occurring, whereas an amplitude signal waveform that is smaller than the waveform from time t_0 to time t_1 is output over the time period from time t_1 to time t_2 during which tube expansion of the weld region 31a occurs.

{0047} Subsequently, over the time period from time t_2 to time t_3 during which tube expansion of the steel tube 30b occurs, the AE sensor 10 outputs a signal waveform with an amplitude that is comparatively weak, as with the waveform output over the time period from t_0 to t_1 above. During the period from time t_3 to t_4 during which cracking occurs during tube expansion in the connection 31b, a signal waveform with a comparatively large amplitude is output. Subsequently, a signal waveform with a comparatively small amplitude is output over the period from time t_4 to t_5 during which tube expansion of the tube 30c occurs. A signal waveform with a small amplitude is again output over the time period from time t_5 to t_6 during which the subsequent weld region is undergoing tube expansion (not shown in the figure).

{0048} The waveform shown in Figure 6(b) is the output signal from the absolute value processor 101, and results from removing the direct current component of the output signal from the AE sensor 10, and performing absolute value conversion. The waveform represented by the solid line in Figure 6(c) is the output signal from the envelope detector 106, and is produced as a result of processing the envelope from the outputs of the absolute value processor 101 in the manner described below.

{0049} Specifically, the periods from time t_1 to time t_2 , time t_3 to time t_4 , and time t_5 to time t_6 , are times when tube expansion is occurring in weld regions 31a, 31b, 31c... of the long tube, or times when aberrations are occurring. The envelopes for these times produce the waveforms represented by the broken lines in Figure 6(c), but the waveforms represented by said broken lines are not output in these time periods. Rather, values interpolated from the change in envelope intensity at a time before, after, or before and after (represented by the solid lines in the figure) are output as the envelope intensity A_t for said time points.

{0050} For example, when the difference or ratio of the actual calculated value and the predicted value determined from the change in the envelope using the aforementioned standard exceeds a predetermined range, said predicted value is used instead of said actual value. Thus, the envelope intensities during tube expansion in the weld regions and during quality aberration will be far outside the values predicted from the transition of the envelope intensity during tube expansion of the main body of the steel tube, and so the aforementioned predicted values are used instead of the envelope intensity at these times.

{0051} Figure 7(a) shows the output signal from the amplification processor 105. With regard to the output, the amplification processor 105 amplifies the signal shown in Figure 6(b) that is output by the absolute value processor 101 by a degree of amplification that is inversely proportional to the intensity of the envelope detector output represented by the solid line in Figure 6(c) in order to correct for damping of the elastic waves reaching the AE sensor. As is seen in the figure, the degree of amplification of the signal from the absolute value processor 101 is increased by the amplification processor 105 in accordance with the distance of the AE sensor from the site of tube expansion. An output is thus made after correcting for damping of the elastic waves produced by tube expansion.

{0052} Figure 7(b) shows the output signal from the comparative processor 103. The comparative processor 103 outputs a "Hi" signal when the output of the amplification processor exceeds the aforementioned aberration decision standard value Th_2 , and thus outputs pulse signals P1 to P3 which are high value generation signals during the period from time t_3 to t_4 . The notification means 110 receives said high value generation signals, and uses sound or display to make a notification as to the occurrence of quality aberration.

{0053} In addition, a pulse counting processor is provided between the aforementioned comparative circuit part 103 [sic] and the aforementioned notification means 110, whereby the number of the aforementioned high value generation signals from the comparative processor 103 is counted. This number is then transmitted to the notification means 110. The notification means 110, thus renders notification regarding the occurrence of quality aberration and the degree of quality aberration based on the number of the high value generation signals.

{0054} Meanwhile, a peak value detector is provided that detects the maximum value for the amplification circuit output immediately after the point when the high value generation signal is output from the aforementioned comparative circuit 103. The notification means 110 thus renders notification as to the occurrence of quality aberration, and the degree of quality aberration based on the magnitude of said peak value.

{0055} Figure 8 is an output waveform diagram for each of the processors when cracking occurs during actual tube expansion of the steel tube. Specifically, the figure is an output waveform diagram when quality inspection is actually being carried out according to the present invention using the configuration described in Figure 1 and Figure 2(a). In (a), the high-amplitude output waveforms occurring approximately at times t_1 , t_2 and t_3 are generated due to the occurrence of cracking at these time points.

{0056} As is clear from the figures, when the aforementioned aberration decision standard value Th_1 is set to $5x$ the value of the amplitude A_s of the AE sensor at time t_s in the initial period of tube expansion using the aforementioned aberration decision standard value setting part 102, the comparative processor 103, as shown in (b) generates pulse signals which are the aforementioned high value generation signals, the first being close to time t_1 , the second being close to time t_2 and the third being close to time t_3 . Consequently, the notification means sends notification of aberration occurrences at these time points t_1 , t_2 and t_3 .

{0057} The present invention is not restricted by the embodiments described above, and various modifications are possible within a range that does not exceed the scope of the invention. For example, it goes without saying that the steel tube that is the subject of inspection is not restricted to one that has weld regions. The site of attachment of the AE sensor is also not restricted to the side surface of the tube, as the sensor may be attached at the end surface. In the embodiments described above, the tube expansion mandrel had a tapered region, but mandrels are not restricted to this type. For example, a tube expansion mandrel can be used that has expanding diameter rollers present on the

outer surface of the mandrel, so that the internal wall of the steel tube is pressed outwards in a radial direction by means of said expanding diameter rollers.

{0058} On the other hand, regarding setting of the aforementioned aberration decision standard value, modes are not restricted to the process represented in the embodiment, and the value may be set to a value that is between the amplitude of the signal determined when normal tube expansion is occurring and the amplitude of the signal determined when quality aberration occurs. In addition, in the aforementioned embodiment, processing performed by analog signal processors can be carried out by means of digital signal processing. For example, an A/D converter can be provided after the absolute value processor 101 or the amplification processor 105 so that their outputs are converted to digital signals, which are then subjected to digital signal processing for subsequent processes.

{0059}

{Effects of the Invention} By means of the quality inspection method used during tube expansion described in Claim 1 of the present invention, as tube expansion occurs with movement of the tube expansion mandrel, vibrations are generated at the site of tube expansion. When quality aberrations are generated in the steel tube, the AE sensor signal amplitude increases relative to the amplitude at previous and subsequent time points. By employing this increase, the invention has the merit of allowing determination regarding an occurrence of quality aberration as tube expansion occurs without installing special irradiation devices or drive devices for quality inspection.

{0060} In addition, vibrations generated by tube expansion and by movement of the tube expansion device are transmitted through the steel tube to an AE sensor that is at a location distant from the site where tube expansion is occurring, so that it is possible to perform quality inspection during tube expansion with the inspection device itself fixed at a specific location. In addition, there is also the merit that quality inspection can be carried out as the long steel tube is undergoing expansion. Because the rate of transmission of said vibrations is extremely fast, when quality aberrations such as cracking occur during tube expansion, it is possible to detect the occurrence of quality aberration and the degree of quality aberration nearly simultaneous to its occurrence.

{0061} Moreover, with the quality inspection method used during tube expansion described in Claim 2, in addition to the merits of the quality inspection method described in Claim 1, there is the merit that the degree of quality aberration can be determined simultaneous to the quality aberration with the inspection device itself fixed at a determined location, without requiring the use of special drive devices or irradiation devices for quality inspection.

{0062} Moreover, with the quality inspection method used during tube expansion described in Claim 3, the degree of amplification of the AE sensor is increased in accordance with a continual decrease in AE sensor signal amplitude, or the degree of amplification of the AE sensor signal is decreased in accordance with a continual increase in AE sensor amplitude. By this means, damping of the elastic waves generated due to tube expansion occurring during the time it takes them to reach the AE sensor can be compensated for with high precision, so that it is possible to increase the reliability and accuracy of processing carried out using said AE sensor signal.

{0063} For example, as the tube expansion mandrel becomes increasingly distant from the AE sensor, the decrease in AE sensor signal is compensated for, and thus even with long steel tubes, it is possible to determine the occurrence of quality aberration and the degree of quality aberration with a high level of accuracy. Moreover, because stable determination of the occurrence of quality aberration and the degree of quality aberration is possible with little fluctuation in AE sensor signal amplitude due to change in transmission distance, a quality inspection method for use during tube expansion is provided that increases the reliability of these determinations.

{Brief Description of the Figures}

{Figure 1} Schematic constitutional diagram that presents a summary of the quality inspection method during tube expansion of steel tubes pertaining to the present invention.

{Figure 2} Control block diagram showing an example of the signal processing system for the steel tube quality inspection device used in the present invention.

{Figure 3} Diagram giving a schematic presentation of the signal waveforms for each of the processors of Figure 2(a), (b) and (c), where (a) is the waveform diagram of the output signal from the

AE sensor, (b) is the waveform diagram of the output signal from the absolute value processor and (c) is the waveform diagram of the output signal from the comparative processor.

{Figure 4} Diagram giving a schematic presentation of the signal waveforms for each of the processors for Figure 2(d), where (a) is the waveform diagram of the output signal from the AE sensor, (b) is the waveform diagram of the output signal from the absolute value processor and (c) is the waveform diagram of the output signal from the envelope detector.

{Figure 5} Control block diagram showing an example of a processing system other than that of the steel tube quality inspection device presented in Figure 2(a)-(d).

{Figure 6} Waveform diagrams giving a schematic presentation of the outputs of the constitutive processors for the steel tube quality inspection device shown in Figure 5, where (a) is the waveform diagram of the output signal from the AE sensor, (b) is the waveform diagram of the output signal from the absolute value processor and (c) is the waveform diagram of the output signal from the envelope detector.

{Figure 7} Waveform diagrams giving a schematic presentation of the outputs of the constitutive processors for the steel tube quality inspection device shown in Figure 5, where (a) is the waveform diagram of the output signal from the amplification processor and (b) is the waveform diagram of the output signal from the comparative processor.

{Figure 8} Waveform diagrams for the various processors when cracking occurs during actual tube expansion of a steel tube, where (a) is the output waveform diagram from the absolute value processor amplification processor and (b) is the output waveform diagram from the comparative processor.

{Key}

- 10 AE sensor
- 20 Tube expansion mandrel
- 30 Long tube
- 30a, 30b, 30c... Steel tubes
- 31a, 31b... Weld regions
- 100 Quality inspection device unit
- 101 Absolute value processor
- 102 Aberration decision standard value setting part
- 103 Comparative processor
- 104 Pulse calculator
- 105 Amplification processor
- 106 Envelope detector
- 107 Peak value detector
- 108 Pulse width determination part
- 110 Notification means

[see source for figures]

Figure 1

Figure 3

(a)

AE sensor output

Time

(b)

Absolute value processor output

Time

(c)

Comparative processor output

Time

Figure 5
[see Key above]

Figure 2
[see Key above]

Figure 4
(a)
AE sensor output
Time
(b)
Absolute value processor output
Time
(c)
Envelope detector output
Time

Figure 6
(a)
AE sensor output
Time
(b)
Absolute value processor output
Time
(c)
Envelope detector output
Time

Figure 7
(a)
Amplification processor output
Time
(b)
Comparative processor output
Time

Figure 8
(a)
Comparative value processor output
Time
(b)
Comparative processor output
Time

Continued from the front page

F Terms (Reference) [see source for codes]

)



AFFIDAVIT OF ACCURACY

I, Kim Stewart, hereby certify that the following is, to the best of my knowledge and belief, true and accurate translations performed by professional translators of the following patents from Japanese to English:

2000-162192

102875

60-208458

2000-94068

2000-107870

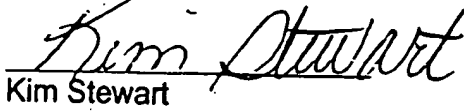

Kim Stewart
TransPerfect Translations, Inc.
3600 One Houston Center
1221 McKinney
Houston, TX 77010

- ATLANTA
- BOSTON
- BRUSSELS
- CHICAGO
- DALLAS
- DETROIT
- FRANKFURT
- HOUSTON
- LONDON
- LOS ANGELES
- MIAMI
- MINNEAPOLIS
- NEW YORK
- PARIS
- PHILADELPHIA
- SAN DIEGO
- SAN FRANCISCO
- SEATTLE
- WASHINGTON, DC

Sworn to before me this
23rd day of January 2002.

Signature, Notary Public

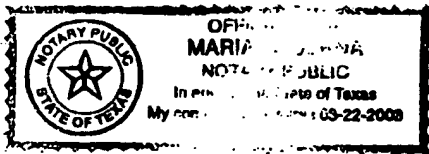

Stamp, Notary Public
Harris County
Houston, TX

記品質異常を判定した際に検知されるAEセンサ信号の振幅の大きさ、AEセンサ信号の振幅が増大した回数若しくはAEセンサ信号の振幅が増大した時間に基づいて前記鋼管の品質異常の程度を判定するようによれば、前記AEセンサ信号の振幅の大きさに基づいて前記鋼管の品質異常の程度を判定でき、前記AEセンサ信号の振幅が増大した回数に基づいて前記鋼管の品質異常の程度を判定することができ、若しくは、AEセンサ信号の振幅が増大した時間に基づいて鋼管の品質異常の程度を判定することができる。

【0010】更に、請求項3に記載の発明のように、拡張マンドレルが鋼管の内部を移動しながら拡張する際に検出されるAEセンサの信号を増幅すると共に、AEセンサ信号の振幅の連続的な減少に応じて前記増幅の度合を高め、AEセンサの振幅の連続的な増加に応じて前記増幅の度合を低下させるようにすると良い。

【0011】このように行なう本発明の請求項3に記載の拡張時の品質監視方法によれば、拡張マンドレルが鋼管の内部を移動しながら拡張する際に検出されるAEセンサの信号を増幅すると共に、拡張により発生する振動がAEセンサまで伝搬することによって生じる減衰が大きくなると前記増幅の度合を増加させ、前記減衰が低下すると前記増幅の度合を減少させるように調整するので、拡張により発生する振動がAEセンサまで伝搬することによって生じる減衰が補正され、該補正されたAEセンサ信号に基づいて品質監視が行なわれる。

【0012】ここで、増幅の度合の変化をAEセンサ出力振幅の連続的な減少又は連続的な増加に応じて行なうこととしているのは、拡張により発生する振動の大きさが比較的安定しておりAEセンサの出力振幅が連続的に変化する部位の拡張振動を基準とすることを意味し、例えば、異常発生時のAEセンサ信号振幅の変化のように非連続的な振幅変化については前記増幅度を追従させないことを意味する。このように非連続変化部分を除いたAEセンサ信号振幅の変化に基づいて補正をすることにより、品質異常等が発生して監視時刻のAE信号振幅が一時的に増大又は減少しても誤った補正をすることなく、減衰を適確に補正する。

【0013】

【発明の実施の形態】以下に本発明の好適な実施の形態を図面を参照して詳細に説明する。図1は、本発明に係る鋼管の拡張時の品質監視方法の概念を説明するために示した概略構成図である。長尺管30については、断面を示している。該長尺管30は、比較的短い鋼管30a、30b、30c・・・が接合部31a、31b・・・において接合されたものである。図においては、鋼管の3本分しか示されていないが、更に下方に続いている。

【0014】拡張マンドレル20は図示のようにテーパー部分と円柱部分とを有し、後方(図面においては上方)

から荷重Pを負荷され、前方(図面においては下方)に進行しながら前記テーパー部分により長尺管の内壁面を半径方向外方に押し広げて、前記長尺管30を拡張するものである。AEセンサ10は長尺管の外側面に接触する状態で設置され、前記拡張が行われているときの該外側面の振動を信号に変換するものであり、監視装置本体100に接続されて該信号を出力する。

【0015】図2は、本発明に適用される品質監視装置の信号処理構成例を示す制御ブロック図である。(a)に示す品質監視装置本体100においては、AEセンサ10は絶対値処理部101に接続され、絶対値処理部101は比較処理部103に接続され、異常判定基準値設定部102も比較処理部103に接続され、比較処理部103は告知手段110に接続される。

【0016】前記絶対値処理部101はAEセンサ10の出力信号の直流分を取り除き絶対値化した信号を出力する。前記異常判定基準値設定部102はAEセンサ10の信号振幅の大きさを判断するための閾値である異常判定基準値Th1を設定する部分であり、異常判定基準値Th1は、異常なく拡張が行なわれている時のAEセンサ信号振幅と品質異常が発生したときAEセンサ信号振幅との間の値になるように設定されればよい。

【0017】例えば、基準値設定つまみを設けて拡張対象の鋼管の種類に応じて予め実験的に得られた異常判定基準値を操作者が設定するようにしても良いが、ここでは、該長尺管30の拡張加工を始めた初期段階の時刻tsのAEセンサ信号振幅Asに予め設定した係数k1(但し、k1>1)を乗じた値を自動的に設定する様にする。

【0018】前記比較処理部103は、絶対値処理部101から入力される信号を前記異常判定基準値Th1と比較して、絶対値処理部101の信号が異常判定基準値Th1を超えた場合に高値発生信号を出力する。告知手段110は、前記高値発生信号が入力されたときに、品質異常が発生したものと判定し、その旨を音声或いは表示によって操作者に通知する。

【0019】このようにして、(a)に示すように構成される品質監視装置本体100によって品質監視をすれば、AEセンサ10の信号は直流分を除去され整流され振幅を取得されて、AEセンサ10の信号振幅が異常判定基準値を超えた場合に異常発生が告知される。

【0020】(b)に示す品質監視装置本体100は、図からもわかるように、前記(a)に示す品質監視装置の構成の比較処理部103と告知手段110との間にパルス計数部104が介設されたものである。パルス計数部104は、比較処理部103及び告知手段110と接続される。そして、比較処理部103から受けた前記高値発生信号の回数を計数し、その回数が予め設定した回数以上になった場合に、品質異常発生信号を出力する。ここでは、高値発生信号の発生回数が2回以上になった

ときに、品質異常発生信号を出力することにする。

【0021】従って、(b)に示すように構成される品質監視装置本体100によって品質監視をすれば、AEセンサ10の信号は直流分を除去され整流されてその振幅を取得されて、AEセンサ10の信号振幅が異常判定基準値を超えた回数が2回以上の場合に、品質異常発生旨が告知される。

【0022】更に、この場合に、パルス計数部104は、前記品質異常発生信号に加えて、高値発生信号の回数を告知手段110に伝送し、告知手段110は品質異常発生旨及び高値発生信号の回数に応じた品質異常の程度を告知するするように構成しても良い。例えば、高値発生回数そのものを告知するようによっても良いが、ここでは、2回ないし3回の場合には異常の程度が「弱」である旨を、4回ないし5回の場合には異常の程度が「中」である旨を、6回以上場合には異常の程度が「強」である旨を告知するようにする。

【0023】(c)に示す品質監視装置本体100は、(a)に示す品質監視装置にピーク値検出部107を増設したものである。ピーク値検出部107には絶対値処理部101の出力及び比較処理部103の出力が入力されると共に、告知手段110に接続される。ピーク値検出部107は、前記比較処理部103から前記高値発生信号が出力された場合に、そのときの絶対値処理部101の出力のピーク値を保持し、前記告知手段110に出力する。

【0024】そして、告知手段110は、品質異常の発生旨及び前期ピーク値に基づいて品質異常の程度を告知する。例えば、ピーク値の大きさそのものを告知するようによっても良いが、ここでは、ピーク値の大きさにより異常の程度を「強」、「中」又は「弱」に判別し、その判別結果を告知するようにする。

【0025】(c)に示すように構成される品質監視装置本体100によって品質監視をすれば、AEセンサ10の信号は直流分を除去され整流されて振幅を取得されて、AEセンサ10の信号振幅が異常判定基準値 T_{h1} を超えた場合には、異常発生旨と該品質異常が発生したときのAEセンサ信号振幅のピーク値に基づく品質異常の程度とが、音声又は表示によって通知される。

【0026】(d)に示す品質監視装置本体100は、(a)に示す品質監視装置の絶対値処理部101と比較処理部103との間に包絡線検波部106を増設し、比較処理部103と告知手段110との間にパルス幅判定部108を増設したものである。前記包絡線検波部106は、絶対値処理部101の出力信号の各種大値を結ぶ包絡線信号を出力し、比較処理部103に伝送する。比較処理部103は、包絡線検波部106の出力が前記異常判定基準値 T_{h1} よりも大きい時に高値発生信号を告知手段110に出力する。パルス幅判定部108は前期高値発生信号の時間が所定の時間よりも長いときには、

異常発生旨及び前記高値発生時間の長さを告知手段110に伝送する。

【0027】そして、告知手段110は、品質異常の発生旨及び前記高値発生信号時間の長さに基づいて品質異常の程度を告知する。例えば、前記高値発生信号時間の長さそのものを告知するようによっても良いが、ここでは、前記高値発生信号時間の長さにより異常の程度を「強」、「中」又は「弱」に判別し、その判別結果を告知するようにする。

【0028】(d)に示すように構成される品質監視装置本体100によって品質監視をすれば、AEセンサ10の信号から直流分を除去され整流された信号の包絡線強度が異常判定基準値を超えた時間を計測し、該時間が所定の時間よりも長い場合に、異常発生旨と包絡線強度が異常判定基準値 T_{h1} を超えた時間に基づく品質異常の程度とが、音声又は表示によって通知される。

【0029】図3は、図2(a)、(b)及び(c)に共通する各処理部の信号波形を概念的に示した図である。図3は、具体的には、図1に示す品質監視構成において、拡張時に接続部31bで品質異常が発生した場合の品質監視装置本体100の各部で出力される波形を示したものであり、(a)はAEセンサ10の出力信号を示し、(b)は絶対値処理部101の出力信号を示し、(c)は比較処理部103の出力信号を示す。

【0030】(a)に示す波形を順に説明する。時刻 t_0 に拡張マンドレル20の進行によって拡張加工が開始すると、該進行時の拡張マンドレル10と長尺管30との摩擦による振動及び拡張による塑性変形等によって生じるいわゆるアコースティックエミッション(AE)による振動等(以下、これらをまとめて拡張振動という。)が発生する。この拡張振動は品質異常が発生していない場合には、比較的弱い弾性波である。従って、鋼管30aの拡張中である時刻 t_0 から t_1 までの時間には、AEセンサ10は比較的小さい振幅の信号波形を出力する。

【0031】次に、接合部31aの拡張をする時刻 t_1 から t_2 の時間は、該接合部31aは例えばメカジョイント、拡散接合、溶接等により接合されており、その硬度が鋼管30aよりも高いため拡張マンドレル20の進行が遅くなり、前記拡張振動は、更に弱い振幅の振動となるため、この時間はAEセンサ10は時刻 t_0 から t_1 よりも小さい振幅の信号波形を出力する。鋼管30bを拡張する時刻 t_2 から t_3 までの時間には、前記時刻 t_0 から t_1 までの時間と同様に、AEセンサ10は比較的弱い振幅の信号波形を出力する。

【0032】そして、次の接合部31bの拡張中にひび割れが発生すると、その破壊によりエネルギーが解放され比較的大きな振幅の弾性波が生じる。AEセンサ10は該弾性波を含む拡張振動を検出して、時刻 t_3 から t_4 の時間には、比較的大きな振幅の信号波形を出力す

る。以降、図からわかるようにAEセンサ10は、鋼管31cを拡張する時刻t4からt5の間には比較的小振幅の信号波形を、図示しないその次の接合部を拡張する時刻t5からt6の間は更に小さい振幅の信号波形を出力する。

【0033】一方、絶対値処理部101の出力波形は、(a)に示すAEセンサ出力の直流分を除去し絶対値化したものであり、(b)に示す如き波形となる。また、比較処理部103は、前記絶対値処理部101の出力信号を前記のように設定された異常判定基準値 $Th1$ と比較して、該基準値 $Th1$ よりも大きいときには「Hi」を出力し、該基準値よりも小さいときには「Lo」を出力する。

【0034】従って、比較処理部103は、(b)に示す絶対値処理部101の出力信号が入力されると、

(c)に示す波形を出力する。時刻t0からt3の間は、絶対値処理部101からは前記異常判定基準値 $Th1$ よりも大きな入力がないので出力は「Lo」のみである。次に、前記のように時刻t3からt4の間にひび割れが発生するので、(b)に示すように、前記異常判定基準値 $Th1$ よりも大きな振幅の信号が入力され、

(c)において時刻t3からt4の間に、パルスP1からP3を出力する。続いて、時刻t4からt6の間は、前記基準値 $Th1$ よりも大きな入力がないので、再び「Lo」のみである。

【0035】図2の(a)ないし(c)の構成を有する品質監視装置本体100の夫々は、これらの図3(a)ないし(c)に示す出力信号に基づいて、次のように処理をする。図2(a)に示す品質監視装置本体100は、比較処理部103から「Hi」のパルスが出力されたので、告知手段110へ異常発生信号を発生し、告知手段110が異常の発生を告知する。

【0036】図2(b)に示す品質監視装置本体100は、比較処理部103から出力されるパルスの回数が3回であり、2回以上に該当するので品質異常発生を行を告知する。また、高値発生信号であるパルスの回数3回に対応する品質異常の程度を告知するようにしても良い。

【0037】図2(c)に示す品質監視装置本体100においては、ピーク値検出部107は、比較処理部103から「Hi」信号が3回出力されるので、夫々のパルス発生時の絶対値処理部101の出力のピーク値PK1ないしPK3を検出し、告知手段110に異常発生信号及びピーク値PK1ないしPK3を伝える信号を送る。告知手段110は、品質異常の発生及び前記ピーク値PK1ないしPK3に対応する品質異常の強弱の程度を、音声あるいは表示により告知する。

【0038】図4は、図2(d)の各処理部の信号波形を概念的に示した図である。図4は、具体的には、図1に示す品質監視構成において、拡張時に接続部31bで

品質異常が発生した場合の品質監視装置本体100の各部で出力される波形を示したものである。(a)はAEセンサ10の出力信号を示し、その波形は図3(a)に等しい。(b)は絶対値処理部101の出力信号を示し、その波形は図3(b)に等しい。(c)は包絡線検波部106の出力波形を示している。

【0039】図2の(d)の構成を有する品質監視装置本体100は、図4に示す信号に基づき、次のように品質異常を検出する。比較処理部103及びパルス幅判定部108により包絡線強度の推移を判定し、該包絡線強度が前記異常判定基準値 $Th1$ よりも大きい時間(比較処理部103が前記高値発生信号を出力する時間であり、図においてTで示される。)が所定の時間よりも長い場合に、告知手段110に異常発生信号及び前記時間Tを伝える信号を送る。告知手段110は、品質異常の発生及び前記時間Tに対応する品質異常の強弱の程度を、音声あるいは表示により告知する。

【0040】図5は、図2(a)～(d)に示した鋼管品質監視装置以外の処理構成例を示す制御ブロック図である。AEセンサ10は、前記長尺管30に着設され、長尺管30の表面の振動を信号に変換し出力する。絶対値処理部101は、AEセンサ10の出力信号の直流分を除去した信号の絶対値を増幅処理部105及び包絡線検波部106に出力する。

【0041】増幅処理部105は絶対値処理部101の出力を増幅する部分であるが、その際に、AEセンサに届く弾性波の減衰を補正するために、包絡線検波部106の出力に基づいて、該増幅度を任意の時刻tの該包絡線強度 A_t に反比例する様にしている。従って、拡張初期の時刻 t_s の包絡線の強度 A_s を基準として、監視時刻tの増幅度は、 A_s/A_t に設定する。

【0042】包絡線検波部106は、絶対値処理部101の出力信号の各種入値を結ぶ包絡線に所定の処理をした信号を出力し、増幅処理部105に伝達する。ここでは、後に詳述するように、母体となる鋼管30a、30b、30c・・・の拡張時であり異常が発生していない時のAEセンサ出力の振幅を前記増幅度補正の指標とするように、包絡線を処理して増幅処理部105に出力する。

【0043】異常判定基準値設定部102は、増幅処理部105の出力信号の振幅の大きさを判断するための閾値である異常判定基準値 $Th2$ を設定する部分である。異常判定基準値設定部102は該長尺管30の拡張加工を始めた初期の時刻 t_s の包絡線検波部106の出力の振幅 A_s に予め設定した係数 $k2$ (但し、 $k2 > 1$)を乗じた値を自動的に設定する。

【0044】前記比較処理部103は、増幅処理部105から入力される信号を前記異常判定基準値 $Th2$ と比較して、増幅処理部105の信号が異常判定基準値 $Th2$ を超えた場合に高値発生信号を出力する。告知手段1

10は、前記高値発生信号が入力されたときに、品質異常が発生した旨を音声或いは表示によって操作者に通知する。

【0045】図6及び図7は、図5に示す各処理構成部の出力を概念的に示した波形図である。具体的には、図1に示す構成で長尺管30の拡張を行なって、接合部32bでひび割れが発生した場合における、図5に示す処理構成の各部の出力波形図である。

【0046】図6(a)に示す信号は、AEセンサ10が長尺管の振動を信号化したものである。この波形は、図3(a)に示す波形と同じであり、全く同様に推移する。即ち、鋼管30aの拡張を行なう時刻t0からt1までは比較的小さい振幅の信号が出力され、接合部31aの拡張をする時刻t1からt2の間は、時刻t0からt1よりも小さい振幅の信号波形を出力する。

【0047】続いて、鋼管30bの拡張を行なう時刻t2からt3までの時間には、前記時刻t0からt1までの時間と同様に、AEセンサ10は比較的小さい振幅の信号波形を出力し、接合部31bの拡張中でありひび割れが発生する時刻t3からt4の間には、比較的大きな振幅の信号波形を出力する。以降、鋼管30cの拡張を行なう時刻t4からt5の間には比較的小さい振幅の信号波形を、図示しないその次の接合部を拡張する時刻t5からt6の間は更に小さい振幅の信号波形を出力する。

【0048】図6(b)に示す波形は、絶対値処理部101の出力信号であり、AEセンサ10の出力信号の直流分を除去した信号を絶対値化したものである。図6

(c)に実線で示す波形は、包絡線検波部106の出力信号であり、絶対値処理部101の出力の包絡線を次のように処理したものである。

【0049】即ち、時刻t1から時刻t2、時刻t3から時刻t4及び時刻t5からt6の間は、長尺管の接合部31a、31b、31c・・・の拡張を行なっている時間又は異常が発生している時間の該包絡線は図6

(c)に破線で示す波形になるが、これらの時間については該破線で示す波形を出力せず、その前、後又は前後の時間の包絡線強度の変化から補間した値(図中実線で示す。)を該当該時刻の包絡線強度A_tとして出力することにする。

【0050】例えば、前記基準の包絡線の推移から求めた予測値と実際の計測値との差又は比が所定の範囲を超えた場合には、該実測値の代わりに該予測値をもちいるようにすればよい。このようにすれば、接合部の拡張時及び品質異常発生時の包絡線強度は母体の鋼管の拡張時の包絡線強度の推移から予測される値を大きく外れるので、これらの時刻の包絡線強度の代わりに前記予測値が使用される。

【0051】図7(a)は、増幅処理部105の出力信号である。この出力は、増幅処理部105が、AEセン

サに届く弾性波の減衰を補正するために、図6(c)に実線で示す包絡線検波部出力の強度に反比例する増幅度で、絶対値処理部101が出力する図6(b)に示す信号を増幅した結果である。図からもわかるように、増幅処理部105は絶対値処理部101の信号を増幅する度合を、拡張中の部位からAEセンサの距離が離れるに応じて高め、拡張による弾性波の減衰を適確に補正して出力する。

【0052】図7(b)は比較処理部103の出力信号を示す。比較処理部103は増幅処理部の出力が前記異常判定基準値Th2を超えるときに「Hi」信号を出力するので、時刻t3から時刻t4の時間に、高値発生信号であるパルス信号P1乃至P3を出力する。告知手段110は、該高値発生信号を受けて、品質異常の発生を音声又は表示により通知する。

【0053】更に、前記比較回路部103と前記告知手段110との間に、パルス計数処理部を設け、比較処理部103からの前記高値発生信号の回数を計数し、その回数を告知手段110に伝え、告知手段110は品質異常発生の際及び高値発生信号の回数に応じた品質異常の程度を告知するようにしてもよい。

【0054】一方、前記比較回路103からの高値発生信号が出力されたときに、その直後の増幅回路出力の極大値を検出し、その値を告知手段に伝えるピーク値検出部を設け、告知手段110は品質異常発生の際及び該ピーク値の大きさに応じた品質異常の程度を告知するようにしてもよい。

【0055】図8は、鋼管を実際に拡張してひび割れが発生したときの各処理部の出力波形図である。具体的には、図1及び図2(a)に記載の構成によって、本発明による品質監視を実際に行なった場合の出力波形図である。(a)において、時刻t1前後、時刻t2前後、時刻t3前後に発生する大きな振幅の出力波形は、これらの時刻に、ひび割れが発生したために生じたものである。

【0056】図からもわかるように、前記異常判定基準値設定部102が、前記異常判定基準値Th1を拡張初期の時刻t_sにおけるAEセンサの振幅A_sの5倍の値に設定すると、比較処理部103は(b)に示すように前記高値発生信号であるパルス信号を時刻t1付近に1回、時刻t2付近に2回、時刻t3に3回発生する。従って、告知手段110は、これらの時刻t1、t2又はt3に異常発生を告知する。

【0057】本発明は、前記した実施の形態に何ら限定されるものではなく、本発明の趣旨を逸脱しない範囲で種々の変更が可能である。例えば、監視対象となる鋼管は接合部を有するものに限られないことは、言うまでもない。AEセンサの取付位置は鋼管の側面に限られず、端面に取り付けてもよい。また、前記実施の形態では、拡張マンドレルをテーパー部分を有する拡張マンドレルと

したが、これに限られるわけではなく、例えば、マンドレルの外側面に拡張ローラを有し、該拡張ローラにより鋼管内壁を半径方向外方に押し広げて拡張を行なう構成の拡張マンドレルとしても良い。

【0058】一方、前記異常判定基準値の設定についても実施の形態で例示した処理に限られず、異常なく拡張が行なわれている時の判定対象となる信号の振幅と品質異常が発生した時の判定対象となる信号の振幅との間の値になるように設定すればよい。更に、前記実施の形態において、アナログ信号処理により行なっている処理を、デジタル信号処理により行なうようにしてもよい。例えば、絶対値処理部101或いは増幅処理部105の後にA/Dコンバータを設けてその出力をデジタル信号に変換し、以降の処理をデジタル信号処理により行なうようにしてもよい。

【0059】

【発明の効果】本発明の請求項1に記載の拡張時の品質監視方法によれば、拡張マンドレルが移動して拡張をするときには、常に拡張部位で振動が発生しており、鋼管に品質異常が発生した際には、AEセンサ信号振幅がその前後の時刻の振幅よりも大きくなることを利用したものであり、品質監視のために特別に励振装置、照射装置等を設けることなく拡張時の品質異常の発生を判定することが可能であるという効果を有する。

【0060】また、かかる拡張装置が移動及び拡張するときに発生する振動は、拡張している部位から離れた位置にあるAEセンサまで鋼管を伝搬して届くので、監視装置全体が一定の場所に静止した状態で拡張時の品質監視を行なうことが可能であり、かつ、長尺の鋼管の拡張時の品質監視が可能であるという効果を有する。更に、該振動が伝搬する速度は非常に速いので、拡張によって例えばひび割れ等の品質異常が発生したときには、発生とほぼ同時に品質異常の発生又はその品質異常の程度を検出することが可能である。

【0061】更に、請求項2に記載の拡張時の品質監視方法によれば、請求項1に記載の品質監視方法の効果に加えて、品質監視のために特別に励振装置、照射装置等を設ける必要がなく、監視装置全体が一定の場所に静止した状態で、品質異常の発生とはほぼ同時に、品質異常の程度を判定することができるという効果を奏する。

【0062】また、請求項3に示す拡張時の品質監視方法によれば、AEセンサ信号の振幅の連続的な減少に応じてAEセンサの増幅の度合を高め、AEセンサの振幅の連続的な増加に応じてAEセンサ信号の増幅の度合を低下させるようにしたので、拡張によって生じる弾性波がAEセンサに届くまでの減衰を高い精度で補正することができ、該AEセンサ信号を用いて行なう処理の確実性及び信頼性を高めることができるという効果を有する。

【0063】例えば、拡張マンドレルがAEセンサから

離れている場合にはAEセンサ信号の低下が補正されるので、より長尺の鋼管においても確実性の高い品質異常の発生判定及び品質異常の程度の判定が可能になる。また、伝搬距離の変動によるAEセンサ信号振幅の変動が小さくなり、品質異常の発生判定及び品質異常の程度の判定の感度が安定するので、これらの判定の信頼性を高めた拡張時の品質監視方法が提供されることになる。

【図面の簡単な説明】

【図1】本発明に係る鋼管の拡張時の品質監視方法の概念を説明するために示した概略構成図である。

【図2】本発明に適用される鋼管品質監視装置の信号処理構成例を示す制御ブロック図である。

【図3】図2(a)、(b)及び(c)に共通する各処理部の信号波形を概念的に示した図であり、(a)はAEセンサの出力信号、(b)は絶対値処理部の出力信号、(c)は比較処理部の出力信号を示す波形図である。

【図4】図2(d)の各処理部の信号波形を概念的に示した図であり、(a)はAEセンサの出力信号、(b)は絶対値処理部の出力信号、(c)は包絡線検波部の出力信号を示す波形図である。

【図5】図2(a)～(d)に示した鋼管品質監視装置以外の処理構成例を示す制御ブロック図である。

【図6】図5に示す鋼管品質監視装置における各処理構成部の出力を概念的に示した波形図であり、(a)はAEセンサの出力信号、(b)は絶対値処理部の出力信号、(c)は包絡線検波部の出力信号を示す波形図である。

【図7】図5に示す鋼管品質監視装置における各処理構成部の出力を概念的に示した波形図であり、(a)は増幅処理部の出力信号、(b)は比較処理部の出力信号を示す波形図である。

【図8】鋼管を実際に拡張してひび割れが発生したときの各処理部の出力波形図であり、(a)は絶対値処理部の出力波形図、(b)は比較処理部の出力波形図である。

【符号の説明】

- 10 AEセンサ
- 20 拡張マンドレル
- 30 長尺管
- 30a、30b、30c、・・・ 鋼管
- 31a、31b、・・・ 接合部
- 100 品質監視装置本体
- 101 絶対値処理部
- 102 異常判定基準値設定部
- 103 比較処理部
- 104 パルス計数部
- 105 増幅処理部
- 106 包絡線検波部

- 107 ピーク検出部
- 108 パルス幅判定部

110 告知手段

【図1】

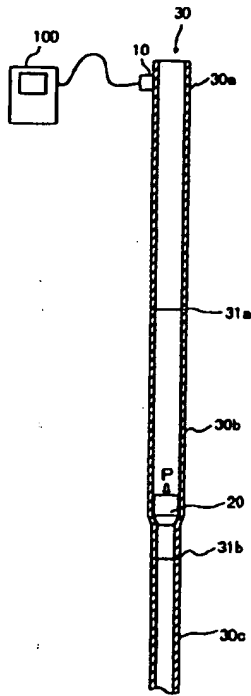

【図3】

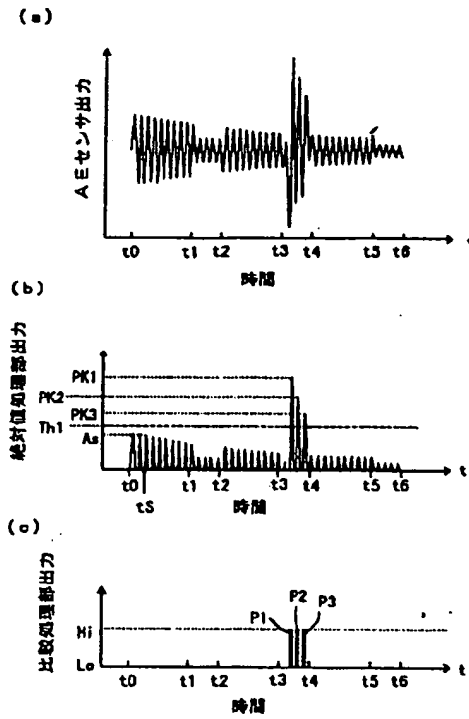

【図5】

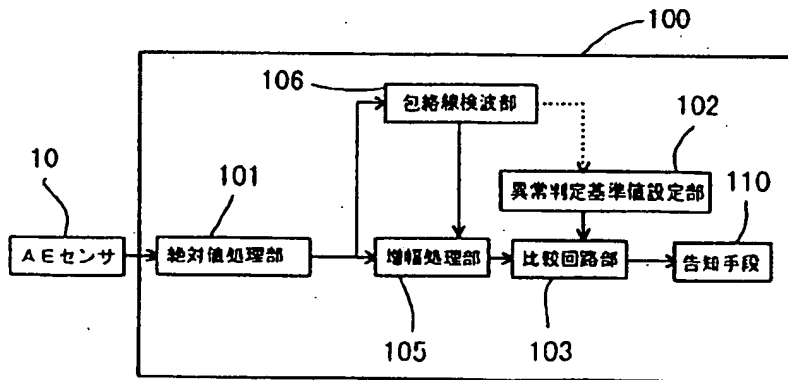

【図2】

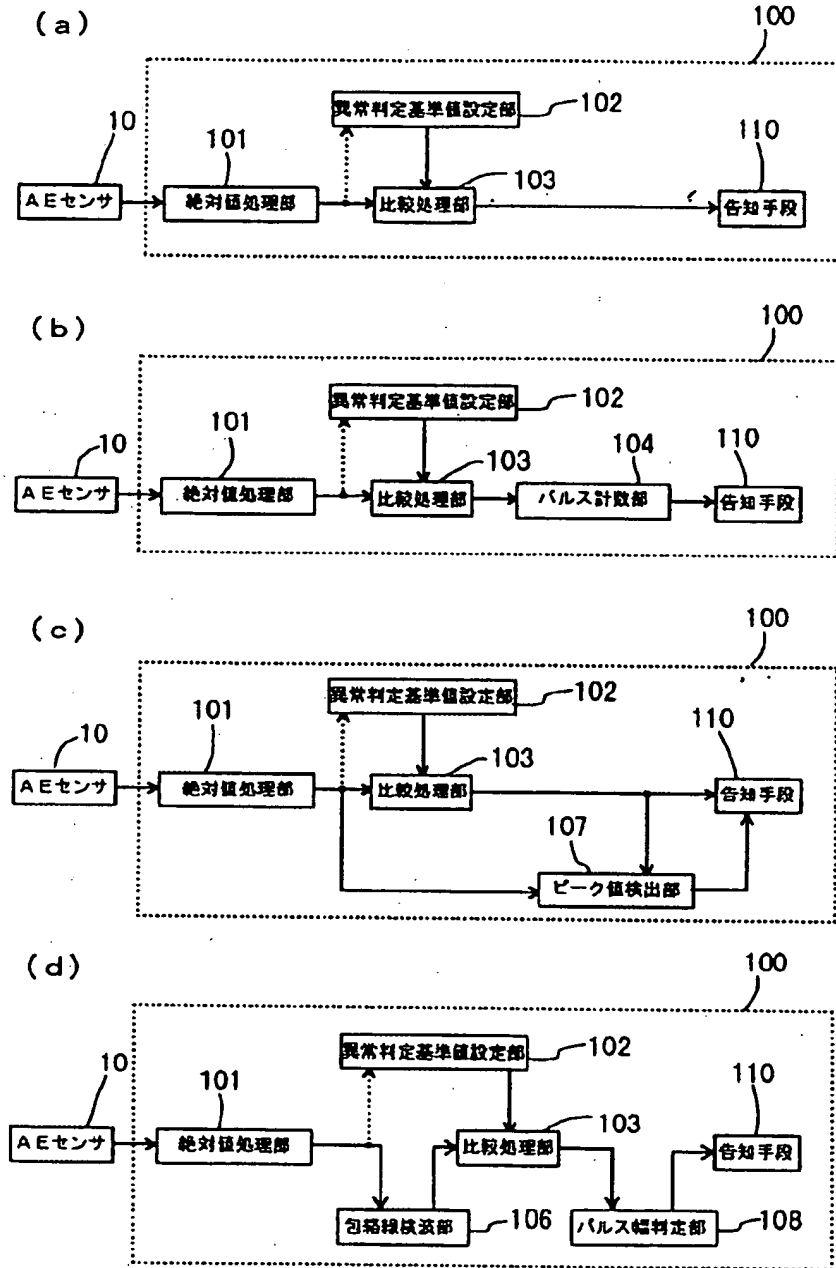

【図4】

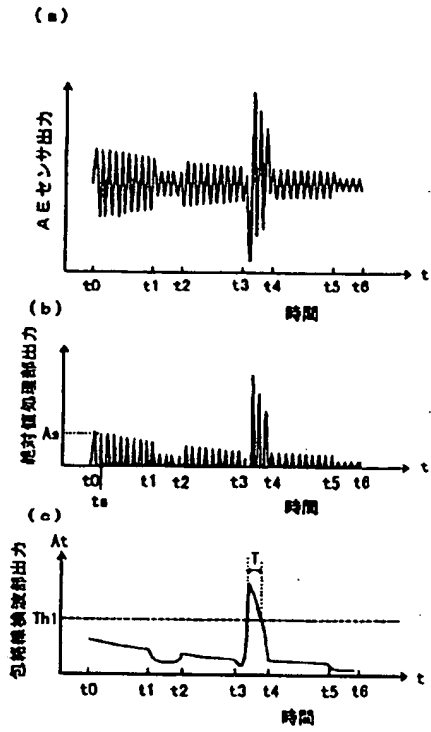

【図6】

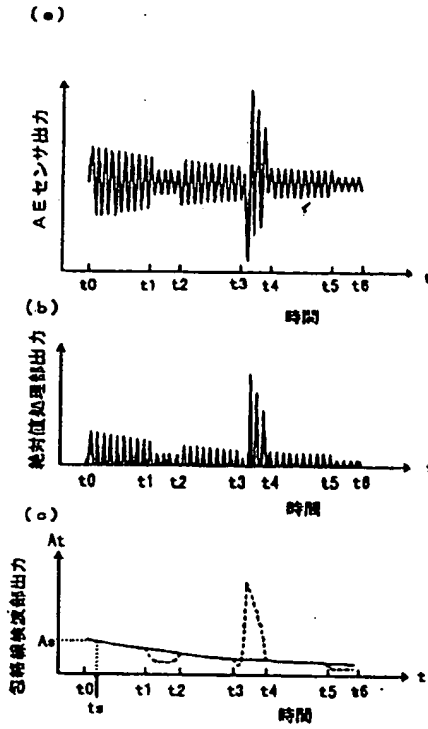

【図7】

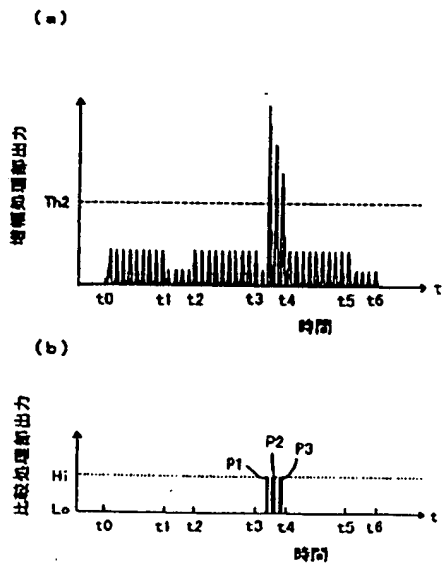

【図8】

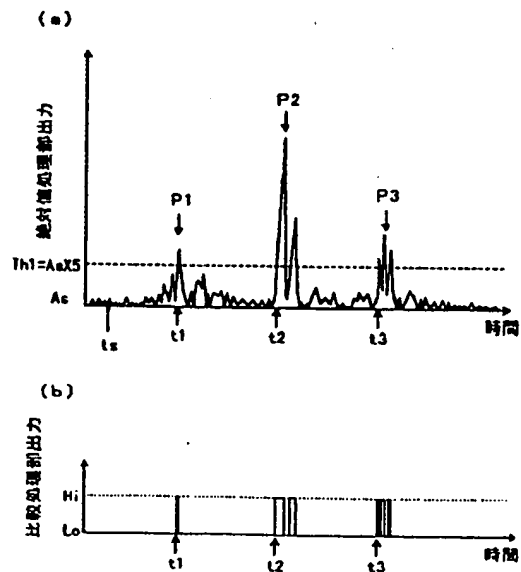

フロントページの続き

ドターム(参考) 2G047 AA07 AB01 AD08 BA05 BC00
BC03 BC07 EA10 EA11 GF06
GF10 GG06 GG09 GG24 GG30
GG33 GG41
2G064 AA04 AB02 AB05 AB08 CC16
CC22 CC26 CC28 CC46 CC54
2G067 AA12 DD13 DD27

(19) Japan Patent Office (JP)
(12) Japanese Unexamined Patent Application Publication (A)
(11) Japanese Unexamined Patent Application Publication 2000-162192
(P2000-162192A)
(43) Disclosure Date: June 16, 2000

(51)	Int. Cl. ⁷	Classification		Theme Codes (Reference)	
		Symbols:	FI:		
	G01N 29/14		G01N 29/14		2G047
	G01H 11/06		G01H 11/06		2G064
	G01M 3/02		G01M 3/02	G	2G067
	3/24		3/24	A	ε

Request for Examination: Not Yet Submitted
Number of Claims: 3
OL
(Total of 11 pages)

(21) Japanese Patent Application: H10-336745
(22) Filing Date: November 27, 1998

(71) Applicant: Daido Steel Co., Ltd. (000003713)
1-11-18 Nishiki, Naka-ku, Nagoya, Aichi Prefecture
(72) Inventor: Ryuzo Yamada
48-1 Nishikatada, Okusa, Chita, Aichi Prefecture
(72) Inventor: Koji Horio
18 Minamishikamochi, Kagiya-machi, Tokai, Aichi Prefecture
(72) Inventor: Takao Hiyamizu
Yagoto San Haitzu 501
2-311 Omoteyama, Tenpaku-ku, Nagoya, Aichi Prefecture
(74) Agent: Noboru Ueno, Patent Attorney (100095669) (and 1 other)

Continued on last page

(54) {Title of the Invention} Quality Inspection Method for Use During Tube Expansion

(57) {Summary}
{Problem}

To offer a quality inspection method for expanded tubes whereby the occurrence of quality aberration or the degree of quality aberration can be determined at the time of expansion of the steel tube, and whereby remote observation is possible.

{Solution} An AE sensor 10, which detects steel tube vibrations during tube expansion occurring as a tube expansion mandrel 20 moves through the interior of a steel tube 30, is situated against the steel tube. Increases in the AE sensor signal amplitude, the number of increases in the AE sensor signal amplitude or the time over which the increase in AE sensor signal amplitude occurs is detected, and the occurrence of quality aberration or the degree of quality aberration in the aforementioned steel tube is determined on the basis of the detected signals.

[see source for diagram]

{Scope of Patent Claims}

{Claim 1} A quality inspection method for use during tube expansion, characterized in that an AE sensor for detecting vibrations in a steel tube during tube expansion of said steel tube is situated against the steel tube, and when tube expansion occurs as a tube expansion mandrel moves through the interior of the steel tube, increases in the AE sensor signal amplitude, the number of increases in the AE sensor signal amplitude or the time over which the increase in AE sensor signal amplitude occurs is detected, and the occurrence of quality aberration in the aforementioned steel tube is determined on the basis of the detected signals.

{Claim 2} The quality inspection method for use during tube expansion according to Claim 1, characterized in that the degree of the quality aberration in the steel tube is determined based on the magnitude of the AE sensor signal amplitude, the number of increases in AE sensor signal amplitude or the time of increase in AE sensor signal amplitude.

{Claim 3} The quality inspection method for use during tube expansion described in Claim 1 or 2, characterized in that the AE sensor signal that is detected during tube expansion is amplified as a tube expansion mandrel moves through the interior of a steel tube, and the level of the aforementioned amplification is increased in accordance with a continual decrease in AE sensor signal amplitude, or the level of the aforementioned amplification is decreased in accordance with a continual increase in AE sensor amplitude.

{Detailed Description of the Invention}

{0001}

{Technological Field of the Invention} The present invention relates to a quality inspection method used during tube expansion. In particular, the invention is a quality inspection method used during tube expansion that is appropriate for inspecting quality aberrations such as cracking or pinholes generated in the joints of long steel tubes, etc., during the expansion of steel tubes.

{0002}

{Prior Art} In the past, the tube expansion of long tubes formed from steel has been carried out using tube expansion mandrels. As shown in Figure 1, this process involves the insertion of a tube expansion mandrel 20 into one of the open ends of a long tube 30, applying a specified weight P in order to insert the tube expansion mandrel 20 into the long tube 30, and pushing the mandrel across the inner wall of the long tube 30 towards the other end, thus performing tube expansion.

{0003} However, there are cases where quality aberrations such as cracks are produced in steel tubes during the tube expansion process. In particular, with tube expansion in steel tubes having mechanical joints or welded regions produced by welding or diffusion welding, quality aberrations readily occur in welded regions. In order to detect these quality aberrations, non-destructive inspections have been traditionally carried out. For example, ultrasonic defect diagnostic methods have been used wherein ultrasound is made to impinge upon the body to be inspected, and internal defects are found based on differences in reflected waves at end surfaces and defect surfaces. In addition, x-ray defect diagnostic methods have been used in which x-rays are made to impinge upon the body to be inspected, and the transmitted radiation is then used to sensitize film, so that the defects can be detected from the photosensitive image thereupon.

{0004} However, in carrying out these inspection methods, there is the problem that at least part of the detection device must be positioned in the region that is to be inspected, and this creates problems that are exacerbated as the length of the tube increases. In addition, there is the problem these inspection methods cannot be carried out on-site during the tube expansion operation, so they must be carried out after completion of tube expansion, at least in the region that is to be inspected. Specifically, with conventional inspection methods, inspection must be carried out with at least part of the inspection device located in the region to be inspected after completion of tube expansion.

{0005} On the other hand, when installing oil well pipes for drawing oil, etc., out of the ground, technologies are known in which tube expansion is carried out by inserting a steel tube with a comparatively small diameter into the ground, and then inserting a tube expansion mandrel, etc., using high downward compressive force, which thereby reduces equipment installation costs. In order to

inspect expanded steel tubes using this conventional method, it is difficult to situate the inspection device at the outer wall surface of the steel tube, and is also difficult to move the inspection device in the lengthwise direction along the outer wall of the steel tube because the tube has been laid underground. Consequently, it has been necessary to inspect the tube by moving the inspection device long the interior of the steel tube. However, the tube diameter is small even after tube expansion, and the total length of the tube can be as long as several kilometers, so there have been extremely difficult problems with quality aberration inspection over the entire length of a steel tube using conventional methods.

{0006}

{Problems to be Solved by the Invention} The problem to be solved by the present invention is that of offering a quality inspection method used at the time of tube expansion, whereby quality aberrations in steel tubes can be evaluated with the inspection device in a stationary condition during the tube expansion process for the steel tube, whereby an occurrence or degree of quality aberration can be determined at a site that is removed from the quality inspection device, and whereby quality aberrations in said steel tube can be detected almost simultaneous to their occurrence.

{0007}

{Means for Solving the Problems} The gist of the present invention used in order to solve these problems relates to a quality inspection method used during tube expansion wherein an AE sensor for detecting vibrations in a steel tube during tube expansion of said steel tube is situated against the steel tube, and when tube expansion occurs as a tube expansion mandrel moves through the interior of the steel tube, increases in the AE sensor signal amplitude, the number of increases in the AE sensor signal amplitude, or the time over which the increase in AE sensor signal amplitude occurs is detected, and the occurrence of quality aberration in the aforementioned steel tube is determined on the basis of the detected signals.

{0008} By means of the quality inspection method used during tube expansion pertaining to the present invention carried out in this manner, vibrations arising on the interior of a steel tube and on the surface of a steel tube during tube expansion occurring as a tube expansion mandrel passes through the interior of a steel tube are detected by an AE sensor situated on the steel tube, and quality aberration is judged to have occurred when an increase amplitude of the aforementioned AE sensor signal is detected, when the number of increases in amplitude of the aforementioned AE sensor signal reaches a predetermined number, or when the time over which the increase in amplitude of the aforementioned AE sensor signal occurs is longer than a predetermined time.

{0009} In addition, as with the invention described in Claim 2, when the degree of quality aberration of the aforementioned steel tube is to be judged based on the magnitude of the increase in AE sensor signal amplitude, the number of increases of AE sensor signal amplitude, or the time of the increase in AE sensor signal amplitude, detected at the time when the aforementioned quality aberration is determined, the degree of the quality aberration of the aforementioned steel tube can be determined based on the magnitude of the aforementioned AE sensor signal amplitude, the number of increases in the aforementioned AE sensor signal amplitude, or time over which the amplitude of the AE sensor signal has increased.

{0010} In addition, as pertains to the invention of Claim 3, the AE sensor signal detected during tube expansion is amplified at the time of tube expansion as the tube expansion mandrel moves long the interior of the steel tube, and the degree of the aforementioned amplification is increased along with a continual decrease in AE sensor signal amplitude, or the degree of the aforementioned amplification is decreased in accordance with a continual increase in AE sensor amplitude.

{0011} With the quality inspection method used during tube expansion described in Claim 3 of the present invention carried out in this manner, the AE sensor signal detected during tube expansion as the tube expansion mandrel moves along the interior of the steel tube is amplified, and as the damping of vibrations generated by the tube as they are conducted to the AE sensor increases, the degree of the aforementioned amplification is increased, or as the aforementioned damping decreases, the degree of the aforementioned amplification is decreased. By this means, damping occurring with transmission of the vibrations generated by tube expansion to the AE sensor is compensated for, and quality inspection is carried out based on said corrected AE sensor signal.

{0012} Employing the change in degree of amplification in accordance with a continual increase or continual decrease in output amplitude from the AE sensor means that the change in tube expansion amplitude in a region in which the output amplitude of the relatively stable AE sensor changes continually is taken as a reference. For example, this means that the aforementioned amplification level is not made to follow discontinuous change in amplitude, as with changes in AE sensor signal amplitude produced during the occurrence of aberration. By excluding these regions of discontinuous change in this manner, correction is carried out based on the change in AE sensor signal amplitude, so that even if the AE signal amplitude increases or decreases over time during the observation period over which quality aberrations, etc. are generated, the attenuation can be appropriately corrected for without erroneous correction.

{0013}

{Embodiments of the Invention} Desirable embodiments of the present invention are described in detail below in reference to the figures. Figure 1 is a schematic constitutional diagram used for schematically presenting the quality inspection method used during tube expansion of steel tubes pertaining to the present invention. A long tube 30 is shown in cross section. Said long tube 30 is a tube produced by welding relatively short steel tubes 30a, 30b, 30c... at weld regions 31a, 31b... In the figure, only three steel tubes are shown, but these tubes continue downwards.

{0014} The tube expansion mandrel 20 has a cylindrical part and a tapered part as shown in the figures, and a load P is applied from behind (upwards in the figure). As the mandrel travels forward (downwards in the figure), the interior wall of the long tube is pressed outwards in a radial direction due to the aforementioned tapered part, thus expanding the aforementioned long tube 30. The AE sensor 10 is situated in contact with the outer wall of the long tube, and the vibrations at said outer surface are converted into signals as the aforementioned tube expansion is taking place. Said signals are output to an inspection device main unit 100 to which it is connected.

{0015} Figure 2 is a control block diagram showing an example of the signal processing structure in the quality inspection device implemented in the present invention. In the quality inspection device main unit 100 shown in (a), the AE sensor 10 is connected to an absolute value processor 101, and the absolute value processor 101 is connected to a comparative processor 103. An aberration decision standard value setting part 102 is also connected with the comparative processor 103, and the comparative processor 103 is connected to a notification means 110.

{0016} The aforementioned absolute value processor 101 removes the direct current component of the output signal from the AE sensor 10, and outputs signals that have been converted into absolute values. The aforementioned aberration decision standard value setting part 102 is the part where the aberration decision standard value Th1 is set, which is the threshold value for determining the size of the signal amplitude from the AE sensor 10. The aberration decision standard value Th1 should be set at a value that is between the AE sensor signal amplitude when tube expansion is occurring without aberration, and the AE sensor signal amplitude when quality aberrations occur.

{0017} For example, the operator uses a standard value setting knob that is provided in order to set the aberration decision standard value obtained experimentally beforehand in accordance with the type of steel tube that is the subject of tube expansion. In this case, the value is automatically set to a value determined by multiplying the AE sensor signal amplitude A_s at time t_s in the initial stage in which the tube expansion process is initially occurring in said long tube 30 by a constant k_1 that has been determined beforehand (where $k_1 > 1$).

{0018} The aforementioned comparative processor 103 compares the signal input from the absolute value processor 101 with the aforementioned aberration decision standard value Th1, and when the signal from the absolute value processor 101 exceeds the aberration decision standard value Th1, a high-value generation signal is output. When the aforementioned high value generation signal is input into the notification means 110, a quality aberration is judged to have occurred, and an indication of this occurrence is sent to the operator by a tone or display.

{0019} In this manner, when quality inspection is to be carried out by the quality inspection device main unit 100 constituted in the manner shown in (a), the direct current component is taken from the signal from the AE sensor 10, and is rectified to obtain an amplitude. When the signal amplitude from

the AE sensor 10 exceeds the aberration decision standard value, a notification is made regarding the occurrence of aberration.

{0020} The quality inspection device unit 100 shown in (b), as can be seen from the figure, has a pulse counting processor 104 between the notification means 110 and the comparative processor 103 constituting the quality inspection device shown in (a) above. The pulse counting processor 104 is connected to the comparative processor 103 and the notification means 110. The number of the aforementioned high value generation signals received from the comparative processor 103 is calculated, and when this number reaches or surpasses the number that has been previously set, a quality aberration occurrence signal is output. In this case, a quality aberration occurrence signal is output when the number of occurrences of high value generation signals is 2 or greater.

{0021} Consequently, when quality inspection is carried out with a quality inspection device unit 100 constituted as indicated in (b), the signal from the AE sensor 10 is removed and rectified, and its amplitude is obtained. When the signal amplitude from the AE sensor 10 exceeds the aberration decision standard value two or more times, notification of an occurrence of quality aberration is made.

{0022} In addition, in this case, the pulse counting processor 104 transmits the number of high value generation signals to the notification means 110 in addition to the aforementioned quality aberration generation signal. The notification means 110 should be constituted in such a manner that notification is made regarding the occurrence of quality aberration, and the degree of quality aberration in accordance with the number of high value generation signals. For example, the device may be constituted so that the number of high value generations itself is made known, but in this case, notification indicating "slight" in regard to the degree of aberration is made when the number is 2 or 3, notification indicating "moderate" is made when the number is 4 or 5, and notification indicating "high" is made when the number is 6 or greater.

{0023} The quality inspection device unit 100 shown in (c) is expanded upon by adding a peak detector 107 to the quality inspection device presented in (a). Output from the absolute value processor 101 and output from the comparative processor 103 is input into the peak value detector 107, and this is linked to the notification means 110. When the aforementioned high value generation signal is output from the aforementioned comparative processor 103, the peak value detector 107 retains the peak value of the output of the absolute value processor 101 at this time, and outputs this value to the aforementioned notification means 110.

{0024} Thus, the notification means 110 reports the degree of quality aberration based on the aforementioned peak value in addition to reporting the occurrence of quality aberration. For example, the magnitude of the peak value itself may be reported, but in this case, notification of a "high", "moderate" or "low" determination is made in regard to the degree of aberration based on the magnitude of the peak value.

{0025} When quality inspection is carried out using the quality inspection device unit 100 constituted as indicated in (c), the signal from the AE sensor 10 is rectified after removing the direct current component, and the amplitude is obtained. When the signal amplitude of the AE sensor 10 exceeds the aberration decision standard value Th_1 , sound or display is used in order to present an indication of an occurrence of aberration and the degree of quality aberration based on the peak value of the AE sensor signal amplitude at the time of occurrence of said quality aberration.

{0026} The quality inspection device unit 100 shown in (d) is a unit in which an envelope detector 106 is also included between the absolute value processor 101 and the comparative processor 103 in the quality inspection device presented in (a), and a pulse width discriminator 108 is also provided between the comparative processor 103 and the notification means 110. The aforementioned envelope detector 106 outputs an envelope signal linking each of the maximum values of the output signals of the absolute value processor 101, and this is transmitted to the comparative processor 103. The comparative processor 103 outputs a high value generation signal to the notification means 110 when the output of the envelope detector 106 is larger than the aforementioned aberration decision standard value Th_1 . The pulse width discriminator 108 transmits an indication of an aberration occurrence and the length of time for the aforementioned high value generation to the notification means 110 when the time of the aforementioned high value generation signal is longer than a determined time period.

{0027} Thus, the notification means 110 performs notification of a quality aberration occurrence and degree of quality aberration based on the length of the aforementioned high value generation signal. For example, notification may be made as to the length of the aforementioned high value generation signal itself, but in this case, notification is made as to the results of determination based on "high", "moderate" or "low" in regard to the degree of aberration determined based on the length of the aforementioned high value generation signal period.

{0028} When quality inspection is carried out with the quality inspection device unit 100 constituted as shown in (d), the direct current component is removed from the AE sensor 100 signal, and the time for which the envelope intensity of the rectified signal exceeds the aberration decision standard value is calculated. If said time is longer than the determined time period, then sound or display is used in order to make a notification regarding quality aberration and the degree of quality aberration determined based on the time that the envelope intensity exceeded the aberration decision standard value $Th1$.

{0029} Figure 3 presents a schematic diagram in which the signal waveform for each of the processors is shown in common for Figure 2a, 2b and 2c. Specifically, Figure 3 shows the waveforms outputs at each part of the quality inspection device unit 100 when a quality aberration has occurred at the connection 31b during tube expansion, for the quality inspection system shown in Figure 1, whereas (a) shows the output signal for the AE sensor 10, (b) shows the output signal for the absolute value processor 101, and (c) shows the output value for the comparative processor 103.

{0030} The waveform shown in (a) will be described in sequence. When the tube expansion process is initiated with advancement of the tube expansion mandrel 20 at time t_0 , vibrations are generated via acoustic emission (AE) arising due to plastic deformation, etc., occurring with tube expansion and vibrations are generated due to friction between the long tube 30 and the tube expansion mandrel 10 as advancement occurs (these vibrations are referred to in combination as "tube expansion vibrations"). When there is no aberration in quality, the tube expansion vibrations give a comparatively weak elastic wave. Consequently, for the period extending from time t_0 to time t_1 during tube expansion of the steel tube 30a, a signal waveform having a comparatively small amplitude is output by the AE sensor 10.

{0031} Next, during the period from time t_1 to time t_2 in which tube expansion of the weld 31a occurs, said weld region 31a has been welded by mechanical joining, diffusion welding or welding, so its hardness is higher than that of the steel tube 30a. As a result, the progress of the tube expansion mandrel 20 slows, and the aforementioned tube expansion vibrations give vibrations of even weaker amplitude. At this time, the AE sensor 10 outputs a signal waveform for vibrations that are smaller from time t_0 to time t_1 . During the time from t_2 to t_3 in which the steel tube 30b expands, the AE sensor 10 outputs a signal waveform with a comparatively weak amplitude as with the time period from time t_0 to t_1 described above.

{0032} When there is a crack generated during tube expansion of the connection 31b, the energy emanates from the crack, and an elastic wave with a comparatively large amplitude is produced. The tube expansion vibrations that include said elastic waves are detected by the AE sensor 10, and during the period from time t_3 to time t_4 , a signal waveform with a comparatively large amplitude is output. Subsequently, as shown in the figure, the AE sensor 10 outputs a signal waveform that has a comparatively small amplitude from time t_4 to time t_5 during tube expansion of the steel tube 31c as shown in the figure. Then a signal waveform with an even smaller amplitude is output from time t_5 to time t_6 during expansion of the next weld region thereof not shown in the figure.

{0033} Meanwhile, the output waveform from the absolute value processor 101 is the absolute value conversion determined after removing the direct current component of the AE sensor output shown in (a), thus producing the waveform shown in (b). In addition, the comparative processor 103 compares the output signal from the aforementioned absolute value processor 101 with the aberration decision standard value $TH1$ set as described above, and a "Hi" signal is output when the value is larger than said standard value $TH1$, whereas a "Lo" signal is output when said value is smaller than said standard value.

{0034} Consequently, when the output signal of the absolute value processor 101 shown in (b) is input, the comparative processor 103 outputs the waveform shown in (c). During the time from time t_0

to time t_3 , the output remains "L" because there is no input from the absolute value processor 101 that is higher than the aforementioned aberration decision standard value TH1. Next, because a crack is generated in the time period from time t_3 to t_4 , a signal having an amplitude that is larger than the aforementioned aberration decision standard value TH1, as shown in (b) is input, and pulses P1 to P3 are output during the time period from time t_3 to t_4 in (c). Subsequently, there is no output that is larger than the aforementioned standard value TH1 during the time period from time t_4 to t_6 , and so the value remains "Lo".

{0035} With the respective quality inspection device units 100 having the constitutions described in (a)-(c) of Figure 2, the following types of processes are carried out based on the output signals shown in (a)-(c) of Figure 3. With the quality inspection device unit 100 shown in Figure 2(a), a "Hi" pulse is output from the comparative processor 103, and an aberration generation signal is output to the notification device 110, so that notification of an occurrence of an aberration is made by the notification means 110.

{0036} With the quality inspection device unit 100 shown in Figure 2(b), the number of pulses output from the comparative processor 103 is 3, and because this corresponds to 2 or more occurrences, notification is made regarding an indication of quality aberration. In addition, notification is also made regarding the degree of quality aberration corresponding to a pulse number of three for the high value signals.

{0037} In the quality inspection device unit 100 shown in Figure 2(c), the peak value detector 107 produces three outputs of "Hi" signals from the comparative processor 103, and so peak values PK1 through PK3 of the absolute value processor 101 output are detected during the pulse generation time. Consequently, an aberration occurrence signal and signals representing the peak values PK1 to PK3 are sent to the notification means 110. The notification means 110 then makes notification, via sound or display, of the occurrence of quality aberration, and the degree of the quality aberration corresponding to the aforementioned peak values PK1 through PK3.

{0038} Figure 4 is a diagram that presents a schematic representation of the signal waveforms for each of the processors in Figure 2(d). Figure 4, specifically, represents the waveform output at each of the parts of the quality inspection device unit 100 when there is a quality aberration at the connection 31b during tube expansion carried out by the quality inspection system presented in Figure 1, whereas (a) represents the output signal of the AE sensor 10, where this waveform is similar to that of Figure 3(a). Here, (b) represents the output signal of the absolute value processor 101, where this waveform is similar to that of Figure 3(b), and (c) represents the output waveform of the envelope detector 106.

{0039} The quality inspection device unit 100 having the constitution of (d) in Figure 2 detects quality aberration in the following manner based on the signals presented in Figure 4. The variation in envelope intensity is determined by the pulse width determination part 108 and the comparative processor 103, and when the time during which said envelope intensity is greater than the aforementioned aberration decision standard value Th1 (time over which the comparative processor 103 outputs the aforementioned high value generation signal; represented by T in the figure) is longer than the predetermined time, an aberration generation signal and a signal that transmits the aforementioned time T is sent to the notification means 110. The notification means 110 then makes a notification, via sound or display, as to the occurrence of quality aberration, and the degree of quality aberration corresponding to the aforementioned time period T.

{0040} Figure 5 is a control block diagram showing a processing system example that is different from the steel tube quality inspection device presented in Figures 2(a)-(d). The AE sensor 10 is attached to the aforementioned long tube 30, and surface vibrations from the long tube 30 are converted to signals that are output. The absolute value processor 101 removes the direct current component of the AE sensor 10 output signal, and outputs the absolute value of the resulting signal to the amplification processor 105 and envelope detector 106.

{0041} The amplification processor 105 is the part that amplifies the absolute value processor 101 output, and in order to correct for attenuation of the elastic waves reaching the AE sensor at this time, said level of amplification is made such that it is inversely proportional to said envelope intensity at any given time t , based on the output of the envelope detector 106. Consequently, the level of

amplification at inspection time t_s is set at A_s/A_t using, as reference, the intensity A_s of the envelope at time t_s during the initial tube expansion period.

{0042} The envelope detector 106 outputs a signal produced by carrying out specified processing on the envelope that links each maximum of the output signals from the absolute value processor 101, and this signal is transmitted to the amplification processor 105. As described in detail below, when no aberrations are being generated during tube expansion of the main steel tube bodies 30a, 30b, 30c..., the envelope is processed taking the amplitude of the AE sensor output as an index of the aforementioned amplification level correction. The result is output to the amplification processor 105.

{0043} The aberration decision standard value setting part 102 is the part whereby the aberration decision standard value Th_2 is set, which is the threshold value for determining the magnitude of the output signal amplitudes from the amplification processor 105. The aberration decision standard value setting part 102 automatically is set to a value found by multiplying the amplitude A_s of the output from the envelope detector 106 at time t_s during the initial period of the tube expansion process of said long tube 30 by a predetermined constant k_2 (where $k_2 > 1$).

{0044} The aforementioned comparative processor 103 compares the signal input from the amplification processor 105 with the aforementioned aberration decision standard value Th_2 , and outputs a high value generation signal when the signal of the amplification processor 105 is greater than the aberration decision standard value Th_2 . The notification means 110 notifies the operator via sound or display as to the occurrence of quality aberration when the aforementioned high value generation signal has been input.

{0045} Figure 6 and Figure 7 are waveform diagrams that give a schematic presentation of the outputs of each of the constitutive processors shown in Figure 5. Specifically, the figures are output waveform diagrams for each of the constitutive processors shown in Figure 5 when cracks occur in the connection 32b along with tube expansion of a long tube 30 having the constitution shown in Figure 1.

{0046} The signal shown in Figure 6(a) is produced by conversion of the vibrations from the long tube into signals by the AE sensor 10. This waveform is the same as the waveform shown in Figure 3(a) and varies similarly. Specifically, an amplitude signal that is comparatively small is output from time t_0 to time t_1 as tube expansion of the steel tube 30a is occurring, whereas an amplitude signal waveform that is smaller than the waveform from time t_0 to time t_1 is output over the time period from time t_1 to time t_2 during which tube expansion of the weld region 31a occurs.

{0047} Subsequently, over the time period from time t_2 to time t_3 during which tube expansion of the steel tube 30b occurs, the AE sensor 10 outputs a signal waveform with an amplitude that is comparatively weak, as with the waveform output over the time period from t_0 to t_1 above. During the period from time t_3 to t_4 during which cracking occurs during tube expansion in the connection 31b, a signal waveform with a comparatively large amplitude is output. Subsequently, a signal waveform with a comparatively small amplitude is output over the period from time t_4 to t_5 during which tube expansion of the tube 30c occurs. A signal waveform with a small amplitude is again output over the time period from time t_5 to t_6 during which the subsequent weld region is undergoing tube expansion (not shown in the figure).

{0048} The waveform shown in Figure 6(b) is the output signal from the absolute value processor 101, and results from removing the direct current component of the output signal from the AE sensor 10, and performing absolute value conversion. The waveform represented by the solid line in Figure 6(c) is the output signal from the envelope detector 106, and is produced as a result of processing the envelope from the outputs of the absolute value processor 101 in the manner described below.

{0049} Specifically, the periods from time t_1 to time t_2 , time t_3 to time t_4 , and time t_5 to time t_6 , are times when tube expansion is occurring in weld regions 31a, 31b, 31c... of the long tube, or times when aberrations are occurring. The envelopes for these times produce the waveforms represented by the broken lines in Figure 6(c), but the waveforms represented by said broken lines are not output in these time periods. Rather, values interpolated from the change in envelope intensity at a time before, after, or before and after (represented by the solid lines in the figure) are output as the envelope intensity A_t for said time points.

{0050} For example, when the difference or ratio of the actual calculated value and the predicted value determined from the change in the envelope using the aforementioned standard exceeds a predetermined range, said predicted value is used instead of said actual value. Thus, the envelope intensities during tube expansion in the weld regions and during quality aberration will be far outside the values predicted from the transition of the envelope intensity during tube expansion of the main body of the steel tube, and so the aforementioned predicted values are used instead of the envelope intensity at these times.

{0051} Figure 7(a) shows the output signal from the amplification processor 105. With regard to the output, the amplification processor 105 amplifies the signal shown in Figure 6(b) that is output by the absolute value processor 101 by a degree of amplification that is inversely proportional to the intensity of the envelope detector output represented by the solid line in Figure 6(c) in order to correct for damping of the elastic waves reaching the AE sensor. As is seen in the figure, the degree of amplification of the signal from the absolute value processor 101 is increased by the amplification processor 105 in accordance with the distance of the AE sensor from the site of tube expansion. An output is thus made after correcting for damping of the elastic waves produced by tube expansion.

{0052} Figure 7(b) shows the output signal from the comparative processor 103. The comparative processor 103 outputs a "Hi" signal when the output of the amplification processor exceeds the aforementioned aberration decision standard value Th_2 , and thus outputs pulse signals P1 to P3 which are high value generation signals during the period from time t_3 to t_4 . The notification means 110 receives said high value generation signals, and uses sound or display to make a notification as to the occurrence of quality aberration.

{0053} In addition, a pulse counting processor is provided between the aforementioned comparative circuit part 103 [sic] and the aforementioned notification means 110, whereby the number of the aforementioned high value generation signals from the comparative processor 103 is counted. This number is then transmitted to the notification means 110. The notification means 110, thus renders notification regarding the occurrence of quality aberration and the degree of quality aberration based on the number of the high value generation signals.

{0054} Meanwhile, a peak value detector is provided that detects the maximum value for the amplification circuit output immediately after the point when the high value generation signal is output from the aforementioned comparative circuit 103. The notification means 110 thus renders notification as to the occurrence of quality aberration, and the degree of quality aberration based on the magnitude of said peak value.

{0055} Figure 8 is an output waveform diagram for each of the processors when cracking occurs during actual tube expansion of the steel tube. Specifically, the figure is an output waveform diagram when quality inspection is actually being carried out according to the present invention using the configuration described in Figure 1 and Figure 2(a). In (a), the high-amplitude output waveforms occurring approximately at times t_1 , t_2 and t_3 are generated due to the occurrence of cracking at these time points.

{0056} As is clear from the figures, when the aforementioned aberration decision standard value Th_1 is set to $5x$ the value of the amplitude A_s of the AE sensor at time t_s in the initial period of tube expansion using the aforementioned aberration decision standard value setting part 102, the comparative processor 103, as shown in (b) generates pulse signals which are the aforementioned high value generation signals, the first being close to time t_1 , the second being close to time t_2 and the third being close to time t_3 . Consequently, the notification means sends notification of aberration occurrences at these time points t_1 , t_2 and t_3 .

{0057} The present invention is not restricted by the embodiments described above, and various modifications are possible within a range that does not exceed the scope of the invention. For example, it goes without saying that the steel tube that is the subject of inspection is not restricted to one that has weld regions. The site of attachment of the AE sensor is also not restricted to the side surface of the tube, as the sensor may be attached at the end surface. In the embodiments described above, the tube expansion mandrel had a tapered region, but mandrels are not restricted to this type. For example, a tube expansion mandrel can be used that has expanding diameter rollers present on the

outer surface of the mandrel, so that the internal wall of the steel tube is pressed outwards in a radial direction by means of said expanding diameter rollers.

{0058} On the other hand, regarding setting of the aforementioned aberration decision standard value, modes are not restricted to the process represented in the embodiment, and the value may be set to a value that is between the amplitude of the signal determined when normal tube expansion is occurring and the amplitude of the signal determined when quality aberration occurs. In addition, in the aforementioned embodiment, processing performed by analog signal processors can be carried out by means of digital signal processing. For example, an A/D converter can be provided after the absolute value processor 101 or the amplification processor 105 so that their outputs are converted to digital signals, which are then subjected to digital signal processing for subsequent processes.

{0059}

{Effects of the Invention} By means of the quality inspection method used during tube expansion described in Claim 1 of the present invention, as tube expansion occurs with movement of the tube expansion mandrel, vibrations are generated at the site of tube expansion. When quality aberrations are generated in the steel tube, the AE sensor signal amplitude increases relative to the amplitude at previous and subsequent time points. By employing this increase, the invention has the merit of allowing determination regarding an occurrence of quality aberration as tube expansion occurs without installing special irradiation devices or drive devices for quality inspection.

{0060} In addition, vibrations generated by tube expansion and by movement of the tube expansion device are transmitted through the steel tube to an AE sensor that is at a location distant from the site where tube expansion is occurring, so that it is possible to perform quality inspection during tube expansion with the inspection device itself fixed at a specific location. In addition, there is also the merit that quality inspection can be carried out as the long steel tube is undergoing expansion. Because the rate of transmission of said vibrations is extremely fast, when quality aberrations such as cracking occur during tube expansion, it is possible to detect the occurrence of quality aberration and the degree of quality aberration nearly simultaneous to its occurrence.

{0061} Moreover, with the quality inspection method used during tube expansion described in Claim 2, in addition to the merits of the quality inspection method described in Claim 1, there is the merit that the degree of quality aberration can be determined simultaneous to the quality aberration with the inspection device itself fixed at a determined location, without requiring the use of special drive devices or irradiation devices for quality inspection.

{0062} Moreover, with the quality inspection method used during tube expansion described in Claim 3, the degree of amplification of the AE sensor is increased in accordance with a continual decrease in AE sensor signal amplitude, or the degree of amplification of the AE sensor signal is decreased in accordance with a continual increase in AE sensor amplitude. By this means, damping of the elastic waves generated due to tube expansion occurring during the time it takes them to reach the AE sensor can be compensated for with high precision, so that it is possible to increase the reliability and accuracy of processing carried out using said AE sensor signal.

{0063} For example, as the tube expansion mandrel becomes increasingly distant from the AE sensor, the decrease in AE sensor signal is compensated for, and thus even with long steel tubes, it is possible to determine the occurrence of quality aberration and the degree of quality aberration with a high level of accuracy. Moreover, because stable determination of the occurrence of quality aberration and the degree of quality aberration is possible with little fluctuation in AE sensor signal amplitude due to change in transmission distance, a quality inspection method for use during tube expansion is provided that increases the reliability of these determinations.

{Brief Description of the Figures}

{Figure 1} Schematic constitutional diagram that presents a summary of the quality inspection method during tube expansion of steel tubes pertaining to the present invention.

{Figure 2} Control block diagram showing an example of the signal processing system for the steel tube quality inspection device used in the present invention.

{Figure 3} Diagram giving a schematic presentation of the signal waveforms for each of the processors of Figure 2(a), (b) and (c), where (a) is the waveform diagram of the output signal from the

AE sensor, (b) is the waveform diagram of the output signal from the absolute value processor and (c) is the waveform diagram of the output signal from the comparative processor.

{Figure 4} Diagram giving a schematic presentation of the signal waveforms for each of the processors for Figure 2(d), where (a) is the waveform diagram of the output signal from the AE sensor, (b) is the waveform diagram of the output signal from the absolute value processor and (c) is the waveform diagram of the output signal from the envelope detector.

{Figure 5} Control block diagram showing an example of a processing system other than that of the steel tube quality inspection device presented in Figure 2(a)-(d).

{Figure 6} Waveform diagrams giving a schematic presentation of the outputs of the constitutive processors for the steel tube quality inspection device shown in Figure 5, where (a) is the waveform diagram of the output signal from the AE sensor, (b) is the waveform diagram of the output signal from the absolute value processor and (c) is the waveform diagram of the output signal from the envelope detector.

{Figure 7} Waveform diagrams giving a schematic presentation of the outputs of the constitutive processors for the steel tube quality inspection device shown in Figure 5, where (a) is the waveform diagram of the output signal from the amplification processor and (b) is the waveform diagram of the output signal from the comparative processor.

{Figure 8} Waveform diagrams for the various processors when cracking occurs during actual tube expansion of a steel tube, where (a) is the output waveform diagram from the absolute value processor amplification processor and (b) is the output waveform diagram from the comparative processor.

{Key}

- 10 AE sensor
- 20 Tube expansion mandrel
- 30 Long tube
- 30a, 30b, 30c... Steel tubes
- 31a, 31b... Weld regions
- 100 Quality inspection device unit
- 101 Absolute value processor
- 102 Aberration decision standard value setting part
- 103 Comparative processor
- 104 Pulse calculator
- 105 Amplification processor
- 106 Envelope detector
- 107 Peak value detector
- 108 Pulse width determination part
- 110 Notification means

[see source for figures]

Figure 1

Figure 3

(a)

AE sensor output

Time

(b)

Absolute value processor output

Time

(c)

Comparative processor output

Time

Figure 5
[see Key above]

Figure 2
[see Key above]

Figure 4
(a)
AE sensor output
Time
(b)
Absolute value processor output
Time
(c)
Envelope detector output
Time

Figure 6
(a)
AE sensor output
Time
(b)
Absolute value processor output
Time
(c)
Envelope detector output
Time

Figure 7
(a)
Amplification processor output
Time
(b)
Comparative processor output
Time

Figure 8
(a)
Comparative value processor output
Time
(b)
Comparative processor output
Time

Continued from the front page

F Terms (Reference) [see source for codes]



AFFIDAVIT OF ACCURACY

I, Kim Stewart, hereby certify that the following is, to the best of my knowledge and belief, true and accurate translations performed by professional translators of the following patents from Japanese to English:

2000-162192

102875

60-208458

2000-94068

2000-107870

Kim Stewart

Kim Stewart

TransPerfect Translations, Inc.
3600 One Houston Center
1221 McKinney
Houston, TX 77010

- ATLANTA
- BOSTON
- BRUSSELS
- CHICAGO
- DALLAS
- DETROIT
- FRANKFURT
- HOUSTON
- LONDON
- LOS ANGELES
- MIAMI
- MINNEAPOLIS
- NEW YORK
- PARIS
- PHILADELPHIA
- SAN DIEGO
- SAN FRANCISCO
- SEATTLE
- WASHINGTON, DC

Sworn to before me this
23rd day of January 2002.

Maria A. Sena

Signature, Notary Public



Stamp, Notary Public
Harris County
Houston, TX